

# Technical Data Hydraulic lift crane

# LR 1280

Litronic®  
Complies with ANSI B 30.5

## Basic machine with undercarriage

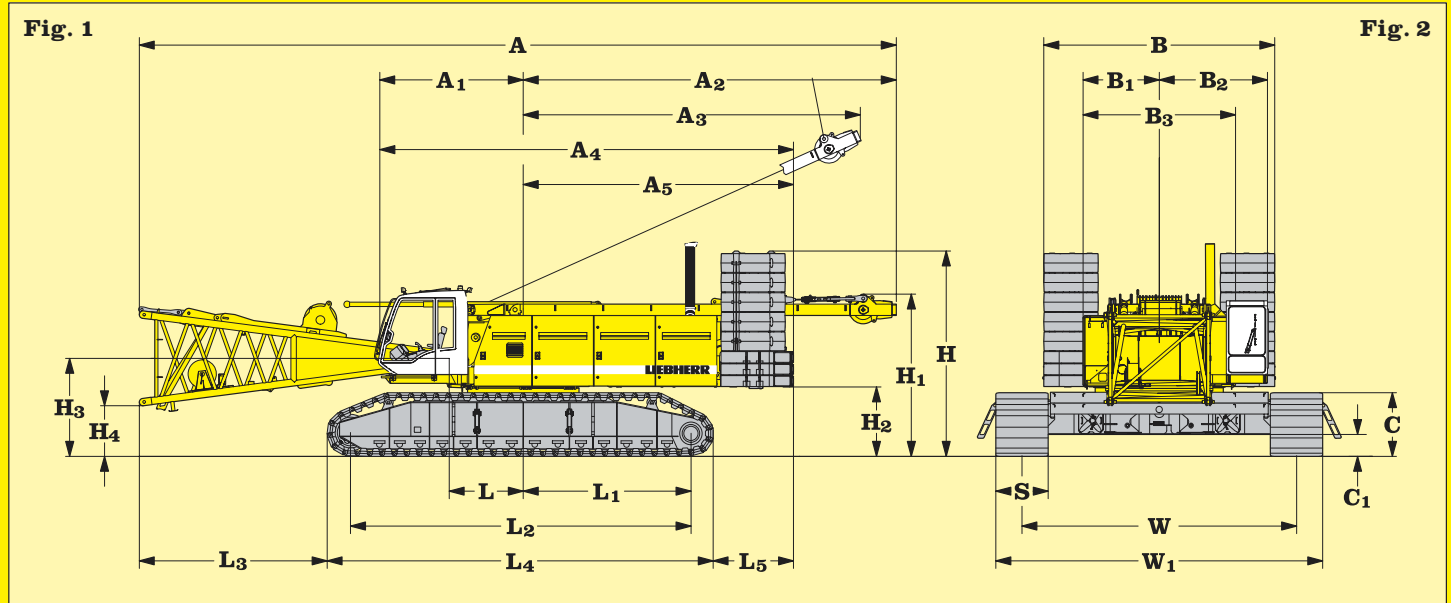

**Fig. 1: Dimensions in \_\_\_\_\_ ft**

<b>A</b> Overall length of superstructure with lowered A-frame and boom foot	57' 1"
<b>A<sub>1</sub></b> Centre of rotation - front edge of cabin	11' 2"
<b>A<sub>2</sub></b> Tail swing - lowered A-frame	28' 1"
<b>A<sub>3</sub></b> Max. tail swing - A-frame in working position	25' 5"
<b>A<sub>4</sub></b> Length of superstructure	31' 6"
<b>A<sub>5</sub></b> Centre rotation - rear counterweight	20' 4"

<b>H</b> Height over counterweight	15' 5"
<b>H<sub>1</sub></b> Height over lowered A-frame	12' 7"
<b>H<sub>2</sub></b> Ground clearance of superstructure	5' 3"
<b>H<sub>3</sub></b> Ground clearance of boom foot pivot	7' 5"
<b>H<sub>4</sub></b> Ground clearance of horizontal boom foot	3' 10"

<b>L</b> Centre of rotation - boom foot pivot	5' 7"
<b>L<sub>1</sub></b> Centre of rotation - centre of tumbler	13' 9"
<b>L<sub>2</sub></b> Wheel base (centre idler to centre tumbler)	25' 11"
<b>L<sub>3</sub></b> Distance from edge of horizontal boom foot to crawler	14' 4"
<b>L<sub>4</sub></b> Length of crawlers	29' 7"
<b>L<sub>5</sub></b> Distance between rear end of crawler and outside of counterweight	5' 4"

**Fig. 2: Dimensions in \_\_\_\_\_ ft**

<b>B</b> Width of counterweight	18' 0"
<b>B<sub>1</sub></b> Centre of rotation - outside of superstructure	5' 9"
<b>B<sub>2</sub></b> Centre of rotation - outside of cabin in working position	8' 2"
<b>B<sub>3</sub></b> Width of superstructure	11' 6"
<b>C</b> Height of crawlers	57"
<b>C<sub>1</sub></b> Ground clearance of undercarriage	20"
<b>S</b> Width of track shoes	47"
<b>W</b> Track width of undercarriage	20' 8"
<b>W<sub>1</sub></b> Width of undercarriage	24' 7"

### Operating weight and ground pressure

The operating weight includes the basic machine with crawlers, 47 inch flat pads, 2 main winches 33,100 lbs and 66 ft main boom (No. 2220.xx) consisting of A-frame, boom foot (23 ft), boom head (23 ft), boom extension (20 ft) 188,500 lbs basic counterweight and 79,400 lbs carbody counterweight and 661,400 lbs hook block.

Total Weight	494,720 lbs
Ground bearing pressure	16.8 psi



**The Better Machine.**

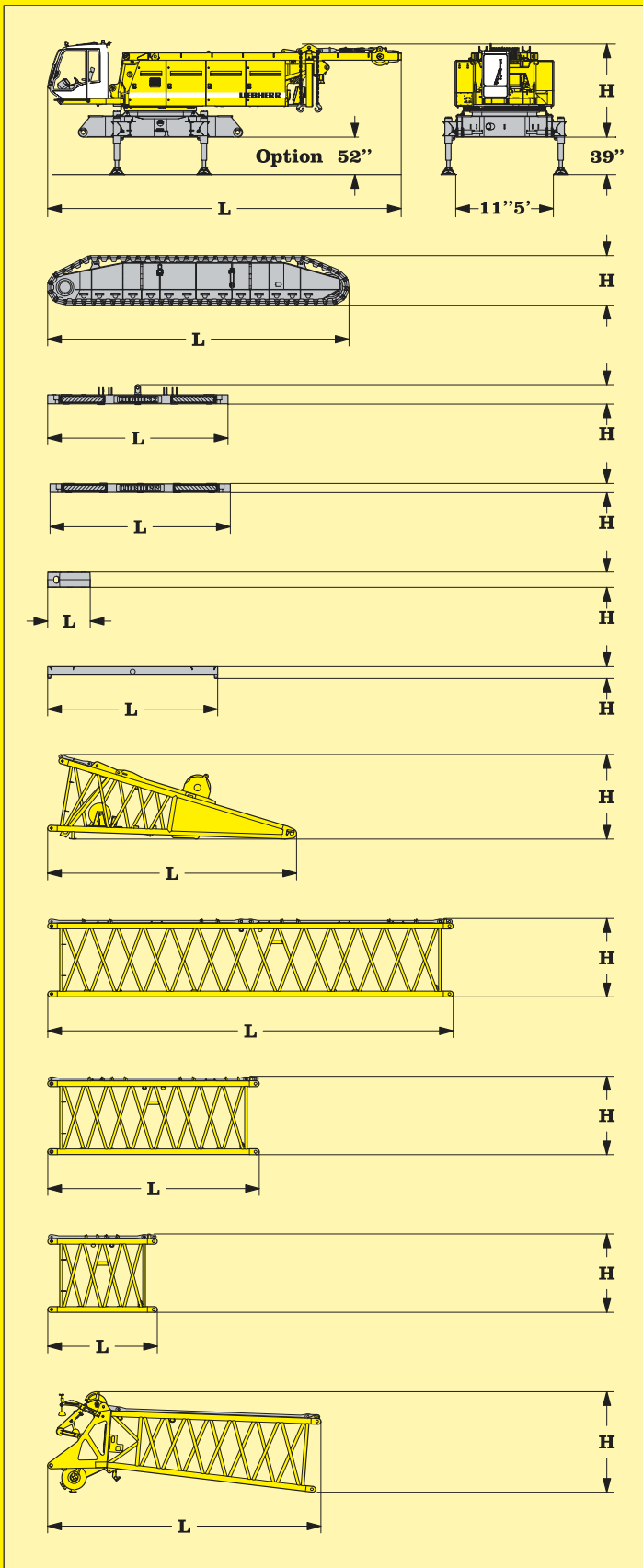

\*) Including pendants

### Basic machine

with A-frame, 2x 33.100 lbs winches, without crawlers, boom foot, basic counterweight and carbody counterweight

L Length	41' 4"
H Height	10' 8"
Width	11' 6"
Weight in lbs	91.710

### Crawler 2x

L Length	29' 6"
H Height	4' 9"
Width	55"
Weight in lbs	45.300

### Counterweight 1x

L Length	18' 0"
H Height	43"
Width	5' 5"
Weight in lbs	29.320

### Counterweight 2x

L Length	18' 0"
H Height	13"
Width	5' 5"
Weight in lbs	23.370

### Counterweight 10x

L Length	59"
H Height	20"
Width	4' 6"
Weight in lbs	11.240

### Carbody counterweight 4x

L Length	16' 5"
H Height	14"
Width	45"
Weight in lbs	20.940

### Boom foot (No. 2220.xx)

L Length	24' 1"
H Height	7' 3"
Width	7' 11"
Weight in lbs	12.390

### Tubular boom section (No. 2220.xx) 38 ft

L Length	39' 1"
H Height	7' 9"
Width	7' 11"
Weight in lbs	6.360

### Tubular boom section (No. 2220.xx) 20 ft

L Length	20' 6"
H Height	7' 3"
Width	7' 11"
Weight in lbs	4.140

### Tubular boom section (No. 2220.xx) 10 ft

L Length	10' 8"
H Height	7' 9"
Width	7' 11"
Weight in lbs	2.490

### Boom head (No. 1311.xx)

L Length	26' 5"
H Height	9' 8"
Width	7' 11"
Weight in lbs	10.340

# Transport dimensions and weights

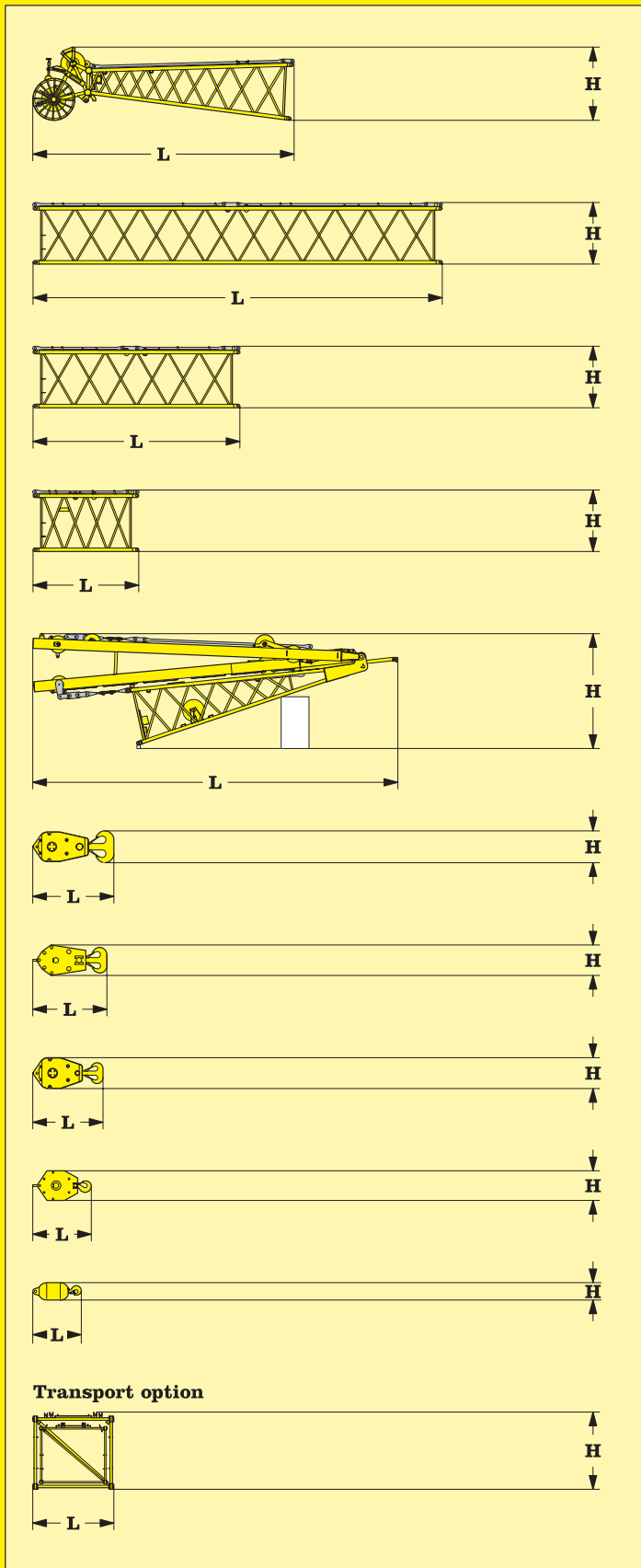

\*) Including pendants

**Jib head (No. 1916.xx)**

L Length	25' 5"
H Height	7' 3"
Width	6' 9"
Weight in lbs	3.420

**Tubular jib section (No. 1916.xx) 38 ft**

L Length	39' 10"
H Height	6'
Width	6' 9"
Weight in lbs	2.760

**Tubular jib section (No. 1916.xx) 20 ft**

L Length	20' 2"
H Height	6'
Width	6' 9"
Weight in lbs	1.520

**Tubular jib section (No. 1916.xx) 10 ft**

L Length	10' 4"
H Height	6'
Width	6' 9"
Weight in lbs	1.200

**Jib foot (No. 1916.xx) with A-frames**

L Length	35' 7"
H Height	10' 4"
Width	6' 9"
Weight in lbs	14.100

**661.400 lbs hook block - 11 sheaves**

L Length	8' 3" - 8' 3"
H Height	32" - 32"
Width	38" - 48"
Weight in lbs	7.050 - 12.125

**330.700 lbs hook block - 5 sheaves**

L Length	7' 0"
H Height	35"
Width	30"
Weight in lbs	8.800

**220.500 lbs hook block - 3 sheaves**

L Length	6' 7"
H Height	35"
Width	27"
Weight in lbs	7.300

**99.200 lbs hook block - 1 sheaves**

L Length	6' 0" - 6' 0" - 6' 0"
H Height	32" - 32" - 32"
Width	11" - 17" - 21"
Weight in lbs	1.760 - 5.130 - 5.290

**35.300 lbs single hook**

L Length	44"
H Height	35"
Width	20"
Weight in lbs	1.990

**Boom - jib transport option**

(No. 2220.xx/1916.xx)	38'/40' - 20'/20' - 10'/10'
Width	41' 0" - 20' 6" - 10' 8"
L Length	7' 11" - 7' 11" - 7' 11"
H Height	7' 9" - 7' 9" - 7' 9"
Weight in lbs	9.100 - 5.650 - 3.700

# Transport dimensions and weights

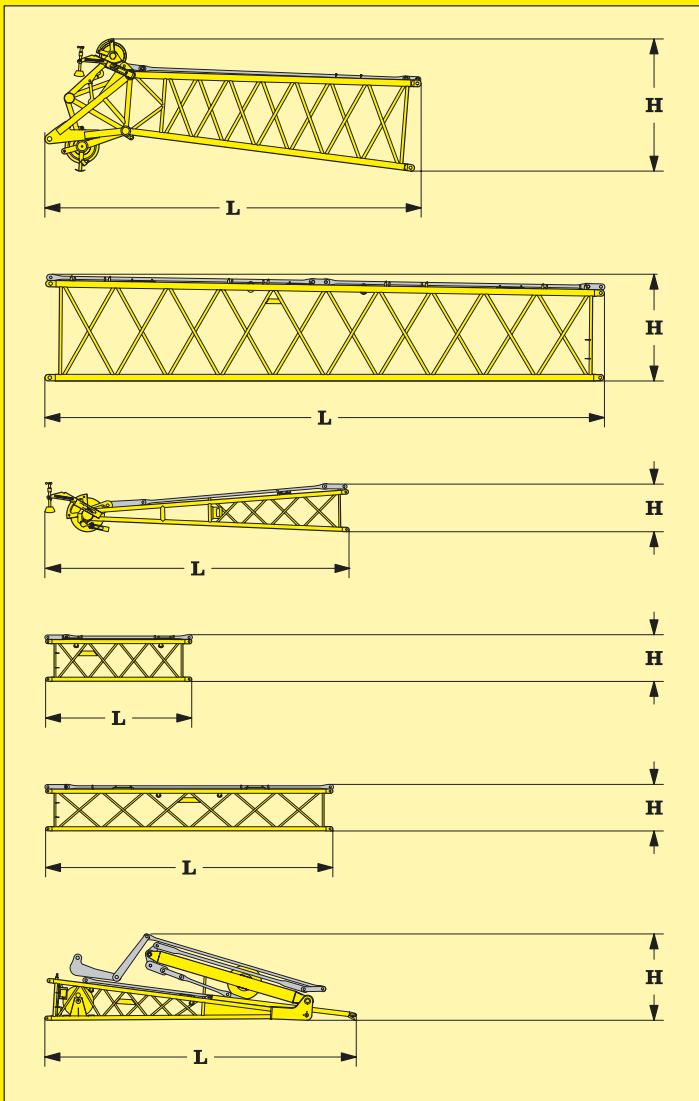

\*) Including pendants

**L – boom head (No. 2018.xx)**

L Length	25' 11"
H Height	8' 10"
Width	7' 6"
Weight in lbs	5.950

**L – boom**

**section tapered (No. 2220.xx / 2018.xx) 38 ft**

L Length	39' 1"
H Height	7' 9"
Width	7' 11"
Weight in lbs	3.840

**Fixed jib head (No. 1008.xx)**

L Length	21' 3"
H Height	40"
Width	43"
Weight in lbs	2.060

**Tubular fixed jib section (No. 1008.xx) 10 ft**

L Length	10' 3"
H Height	40"
Width	43"
Weight in lbs	660

**Tubular fixed jib section (No. 1008.xx) 20 ft**

L Length	20' 1"
H Height	40"
Width	43"
Weight in lbs	1.010

**Fixed jib foot (No. 1008.xx) with A-frames**

L Length	21' 9"
H Height	73"
Width	57"
Weight in lbs	4.300

# Transport dimensions and weights



## Engine

Water cooled, V 8 cylinder Liebherr diesel engine, turbo charged with intercooler, model D 9408 T1-E, power rating according to ISO 9249, 400 hp at 1900 rpm.  
 Fuel Tank: 2x 122 gal capacity with continuous level indicator and reserve warning.



## Hydraulic system

An axial displacement pump supplies the open loop hydraulic system for boom luffing, jib luffing and travel. The main hoist winches and swing are operated in a closed loop system. All functions can be operated simultaneously. To minimize peak pressure an automatic working pressure cut-off is integrated in a pump. All filters are electronically monitored. The use of synthetic environmentally friendly oils (biodegradable) is possible.  
 Max. working pressure: 5000 psi  
 Hydraulic oil tank capacity 248 gal



## Winches

Winch options:  
 Line pull (1<sup>st</sup> layer) \_\_\_\_\_ max. 47.400 lbs  
 Line pull (7<sup>th</sup> layer) \_\_\_\_\_ 33.100 lbs  
 Rope diameter: \_\_\_\_\_ 28 mm  
 Drum diameter: \_\_\_\_\_ 29 inch  
 Rope speed ft/min on average \_\_\_\_\_ 0 - 453  
 Rope capacity 7 layers \_\_\_\_\_ 1870 ft  
 The winches are outstanding in their compact design and easy assembly.  
 Propulsion is via a planetary gearbox in oil bath. Load support by the hydraulic system; additional safety factor provided by a spring loaded, multi-disc holding brake. The main winches use pressure controlled, variable flow hydraulic motors. This system features sensors that automatically adjust oil flow to provide max. winch speed depending on load.  
 Option - winch with freefall system:  
 Clutch and braking functions on the freefall system are provided by a compact designed, low wear and maintenance free multi-disc brake.



## Equipment

- Main boom (No. 2220.xx) max. length \_\_\_\_\_ 296 ft
- High reach (No. 2220.xx / No. 2018.xx) \_\_\_\_\_ 324 ft
- Luffing jib (No. 1916.xx) max. length \_\_\_\_\_ 272 ft
- Max. combination \_\_\_\_\_ boom 181 ft and luffing jib 272 ft (boom 190 ft and luffing jib 233 ft)
- Fixed jib (No. 1008.xx) \_\_\_\_\_ 36 ft - 85 ft
- Auxiliary jib 33 US t lifting capacity
- Hook



## Jib luffing winch

Max. line pull: 23.150 lbs. Rope diameter: 20 mm.  
 51 sec. to boom from 15° to 78°



## Boom luffing winch

Max. line pull: 33.100 lbs. Rope diameter: 24 mm.  
 137 sec. to boom from 15° to 86°



## Swing drive

Consists of rollerbearing with external teeth, swing drive with fixed axial piston hydraulic motor, spring loaded and hydraulically released multi-disc holding brake, planetary gearbox and pinion.  
 Free swing with hydraulic moment control reduces wear to a minimum. A multi-disc holding brake acts automatically at zero swing motion.  
 Swing speed from 0 - 1.8 rpm continuously variable.



## Crawler

Propulsion through axial piston motor, hydraulically released spring loaded multi-disc brake, crawler tracks, hydraulic chain tensioning device.  
 Flat track shoes 35 inch  
 Drive speed 0 - 0.84 mph



## Control

The control system - developed and manufactured by Liebherr - is designed to withstand extreme environmental conditions such as temperature, vibration and electromagnetic interference and to meet all requirements that are needed in heavy duty crane operation.  
 Complete machine operating data are shown on a high resolution display.  
 Standard operational information is displayed by means of graphical symbols, fault indications are displayed in plain text (more than 10 languages available).  
 The cranes are equipped with proportional control for all main movements, which can be carried out simultaneously.  
 A backup control system, that allows limited use of the crane is standard. This feature increases the safety and availability of the crane even further.  
 The crane is operated with 2 multi-directional joysticks, the right for winch I and boom hoisting, the left for winch II and slewing control.  
 Option:  
 Parallel handle bar joysticks for simultaneous winch and luffing jib operation.  
 The crawlers are activated with the two central foot pedals. Additionally, hand levers can be attached to the pedals.



## Remarks

1. The lifting capacities stated are valid for lifting operation only (corresponds with crane classification according to F.E.M. 1.001, crane group A1)
2. Crane standing on firm, horizontal ground.
3. The weight of the lifting device (hoisting ropes, hook block, shackle etc.) must be deducted from the gross lifting capacity to obtain a net lifting value.
4. Additional equipment on boom (e.g. boom walkways, auxiliary jib) must be deducted to get the net lifting capacity.
5. For max. wind speed please refer to lift chart in operator's cab or manual.
6. The slewing speed of the load must not exceed 90 m/min.
7. Working radii are measured from centre of swing and under load.
8. The lifting capacities are valid for 360 degrees of swing.
9. Calculation of stability under load is based on DIN 15019 / part 2 / chart 1 and ISO 4305 Tab1 + 2, tipping angle 4°.
10. The structures are calculated according to F.E.M. 1.001 - 1998 (prEN 13001 / T2 / 1997).



## Noise emission

110 dB (A) at 50 ft - 71 dB (A) inside the cab.

# Technical description

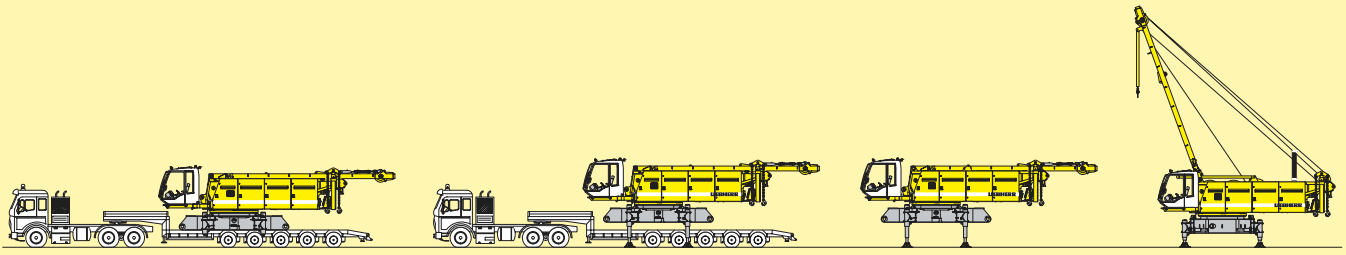

**Unloading of basic machine**

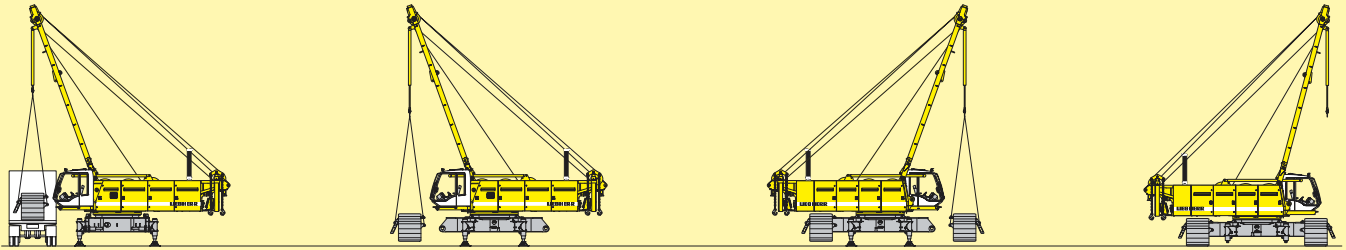

**Unloading and assembly of crawlers**

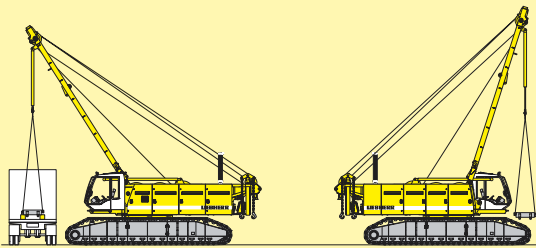

**Unloading and assembly of carbody counterweight**

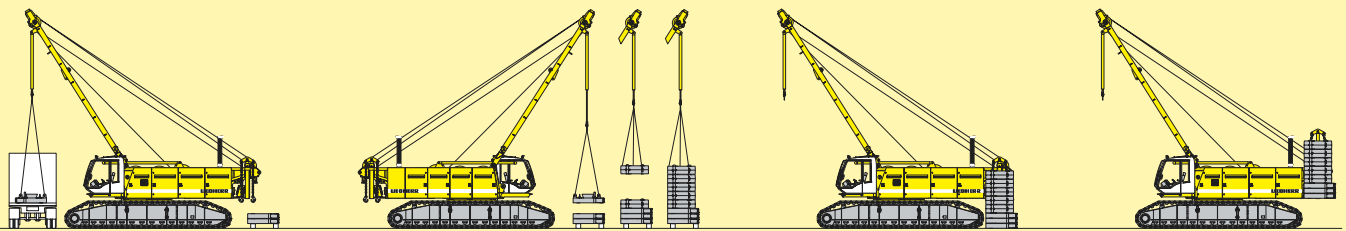

**Unloading and assembly of counterweight**

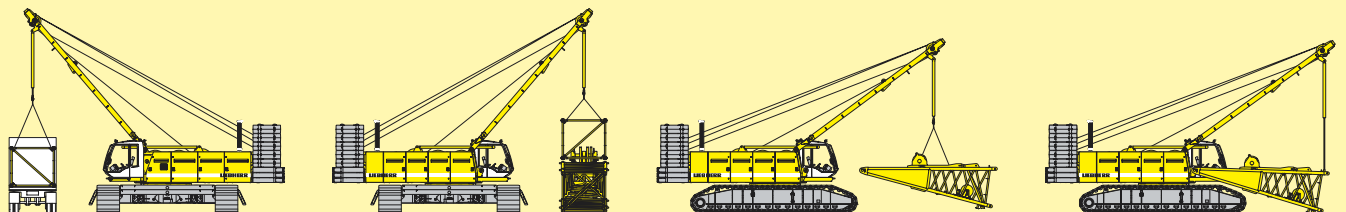

**Unloading and assembly of boom – Assembly of boom foot**

# Self assembly system

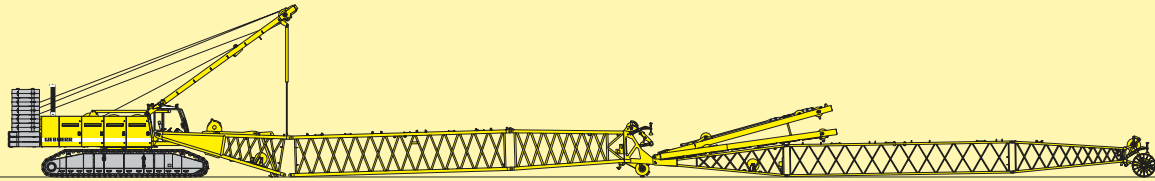

**Assembly of boom**

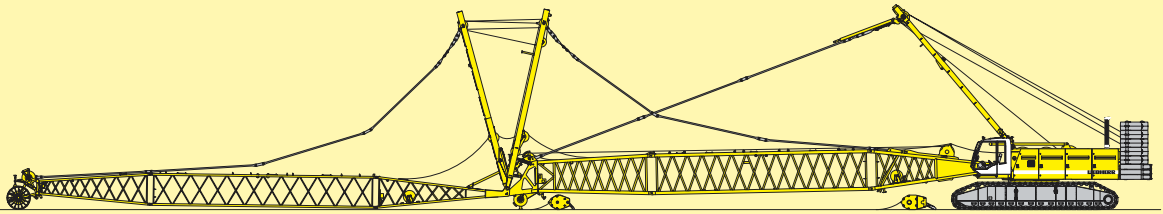

**Reeving of hoist and jib ropes**

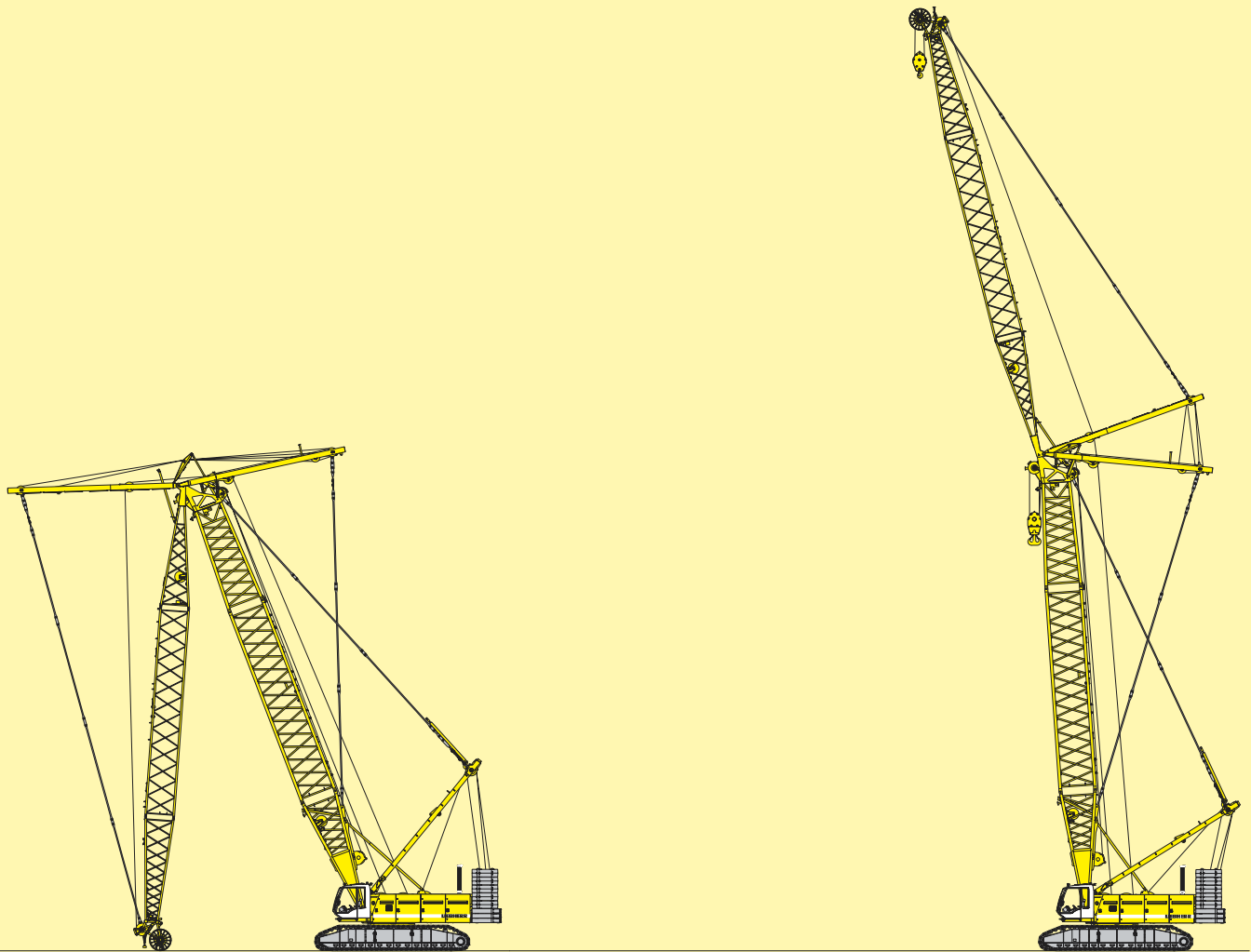

**Luffing of boom and jib**

**Working position**

## **Booming up - crane in working position**

**188.500 lbs counterweight and 79.400 lbs carbody counterweight**

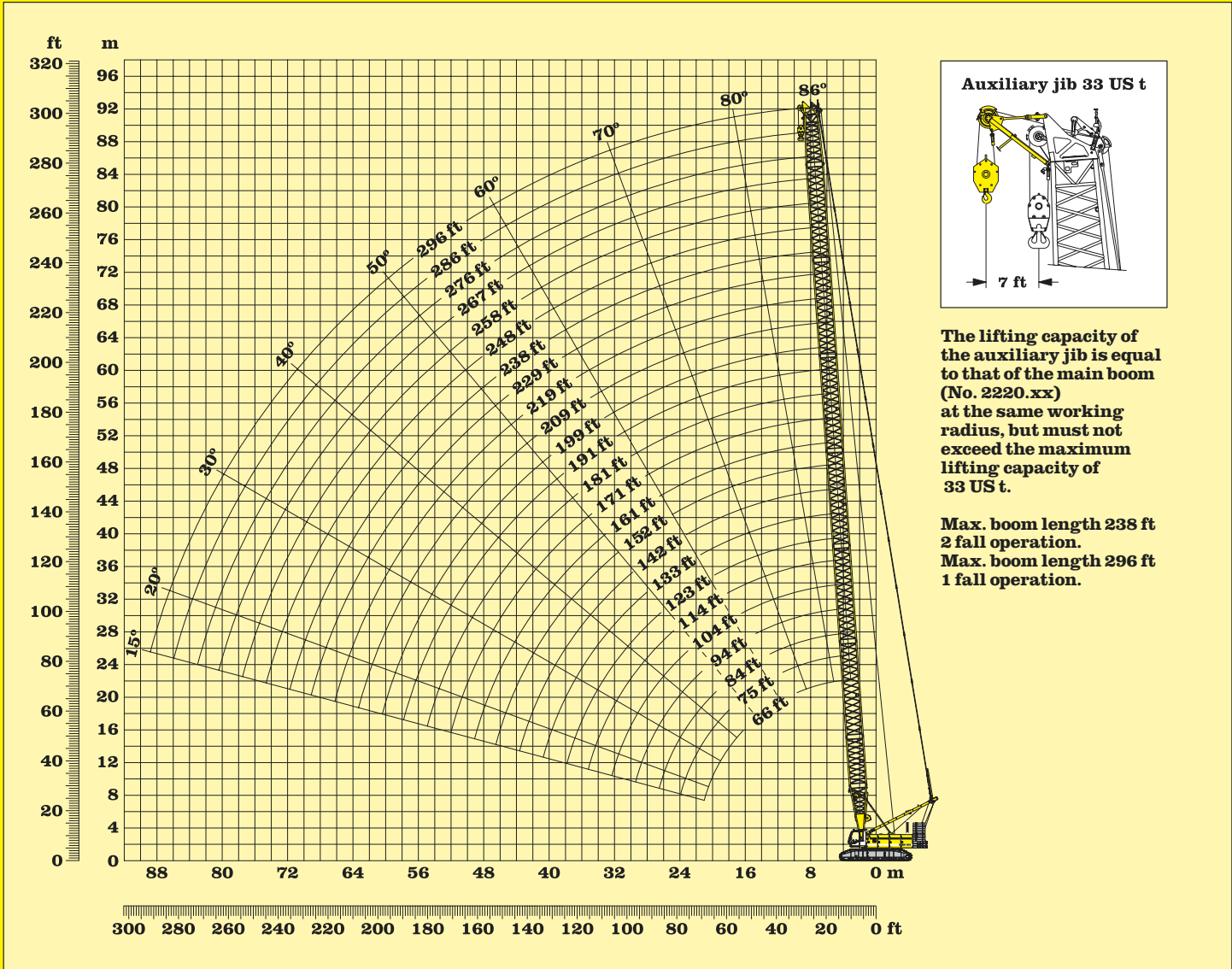

**Boom configuration (Table1 - No. 2220.xx)**

Configuration for boom lengths between 66 ft to 296 ft:

	Length	Number of boom extensions																								
Boom foot	23 ft*	1	1	1	1	1	1	1	1	1	1	1	1	1	1	1	1	1	1	1	1	1				
Boom insert	10 ft*		1		1		1		1		1		1		1		1		1		1					
Boom insert	20 ft*	1	1		1	1		1	1		1	1		1	1		1	1		1	1					
Boom insert	38 ft*			1	1	1	1	2	2	2	2	3	3	3	3	4	4	4	4	5	5	5	5	6	6	6
Boom head	23 ft*	1	1	1	1	1	1	1	1	1	1	1	1	1	1	1	1	1	1	1	1	1	1	1	1	1
Boom length in (ft)		66	75	84	94	104	114	123	133	142	152	161	171	181	191	199	209	219	229	238	248	258	267	276	286	296

\*Actual lengths of boom sections are metric (e.g. 3m, 6m, 11.7 m). The figures shown above are approximate conversions to feet.

**Main boom 66 ft to 296 ft  
working range - 86°-15°**

Capacities in 1000 lbs for boom lengths from 66 ft to 296 ft – with 33.100 lbs winches: counterweight 188.500 lbs and 79.400 lbs carbody counterweight														
Radius (ft)	Boom length in (ft)													Radius (ft)
	66 lbs	84 lbs	104 lbs	123 lbs	142 lbs	161 lbs	181 lbs	199 lbs	219 lbs	238 lbs	258 lbs	276 lbs	296 lbs	
14.1	605.5													14.1
15	605.5													15
20	509.6	502.7	482.9	447.4	416.4									20
25	390.8	418.6	367.2	390.8	379.9	320.3	292.1	236.4	202.8					25
30	320.7	321.3	321.4	209.2	292.5	297.9	275.0	227.8	199.0	166.2	145.0	118.7		30
35	252.0	251.8	252.3	242.8	251.9	238.3	236.2	215.9	189.4	158.7	143.3	117.8	103.3	35
40	206.7	207.2	206.9	206.7	206.3	205.9	205.3	196.5	178.6	154.2	141.8	116.3	101.4	40
45	174.6	175.1	174.8	174.5	174.0	173.5	172.9	172.4	167.1	146.3	138.3	114.9	100.2	45
50	150.7	151.2	150.8	150.5	149.9	149.5	148.8	148.2	147.5	139.9	134.8	113.2	97.0	50
55	132.1	132.6	132.3	132.0	131.0	130.8	130.1	125.2	125.6	128.1	125.1	111.8	95.0	55
60	117.2	117.9	117.5	117.2	116.5	116.0	115.1	114.6	113.8	113.1	111.9	109.0	93.4	60
65	104.9	105.8	105.4	105.1	104.4	103.8	103.1	102.4	101.6	100.9	100.1	96.3	92.1	65
70		95.7	95.4	95.1	94.3	93.8	93.0	92.3	91.5	90.7	89.9	89.0	86.3	70
75		87.1	86.9	86.6	85.8	85.3	84.4	83.8	82.9	82.2	81.3	80.5	78.5	75
80		79.7	79.6	79.3	78.6	78.0	77.1	76.5	75.6	74.8	74.0	73.2	71.8	80
85		73.3	73.2	73.0	72.3	71.7	70.8	70.1	69.2	68.5	67.6	66.8	65.8	85
90			67.7	67.5	66.7	66.2	65.3	64.6	63.7	62.9	62.0	61.2	60.3	90
95			62.8	62.6	61.9	61.3	60.4	59.7	58.8	58.0	57.1	56.3	55.4	95
100			58.3	58.2	57.5	57.0	56.1	55.4	54.5	53.7	52.8	52.0	51.0	100
105				54.3	53.7	53.1	52.2	51.5	50.6	49.8	48.9	48.1	47.1	105
110				50.8	50.2	49.6	48.7	48.0	47.1	46.3	45.4	44.5	43.6	110
115				47.6	47.0	46.5	45.6	44.9	43.9	43.2	42.2	41.4	40.4	115
120				44.7	44.1	43.6	42.7	42.0	41.1	40.3	39.3	38.5	37.5	120
140					34.6	34.3	33.4	32.9	31.9	31.2	30.2	29.4	28.4	140
160						27.4	26.7	26.0	25.1	24.3	23.3	22.5	21.5	160
180							21.3	20.7	19.8	19.1	18.1	17.2	16.2	180
200								16.4	15.6	14.9	13.9	13.1	12.1	200
215									12.9	12.3	11.3	10.5	9.5	215
235										9.2	8.3	7.5	6.5	235
255											5.8	5.0	4.1	255
270												3.4	2.4	270

Above lift chart is for reference only. For actual lift duty please refer to lift chart in operator's cab or manual.

# Lift chart for crane configuration

**188.500 lbs counterweight and 79.400 lbs carbody counterweight**

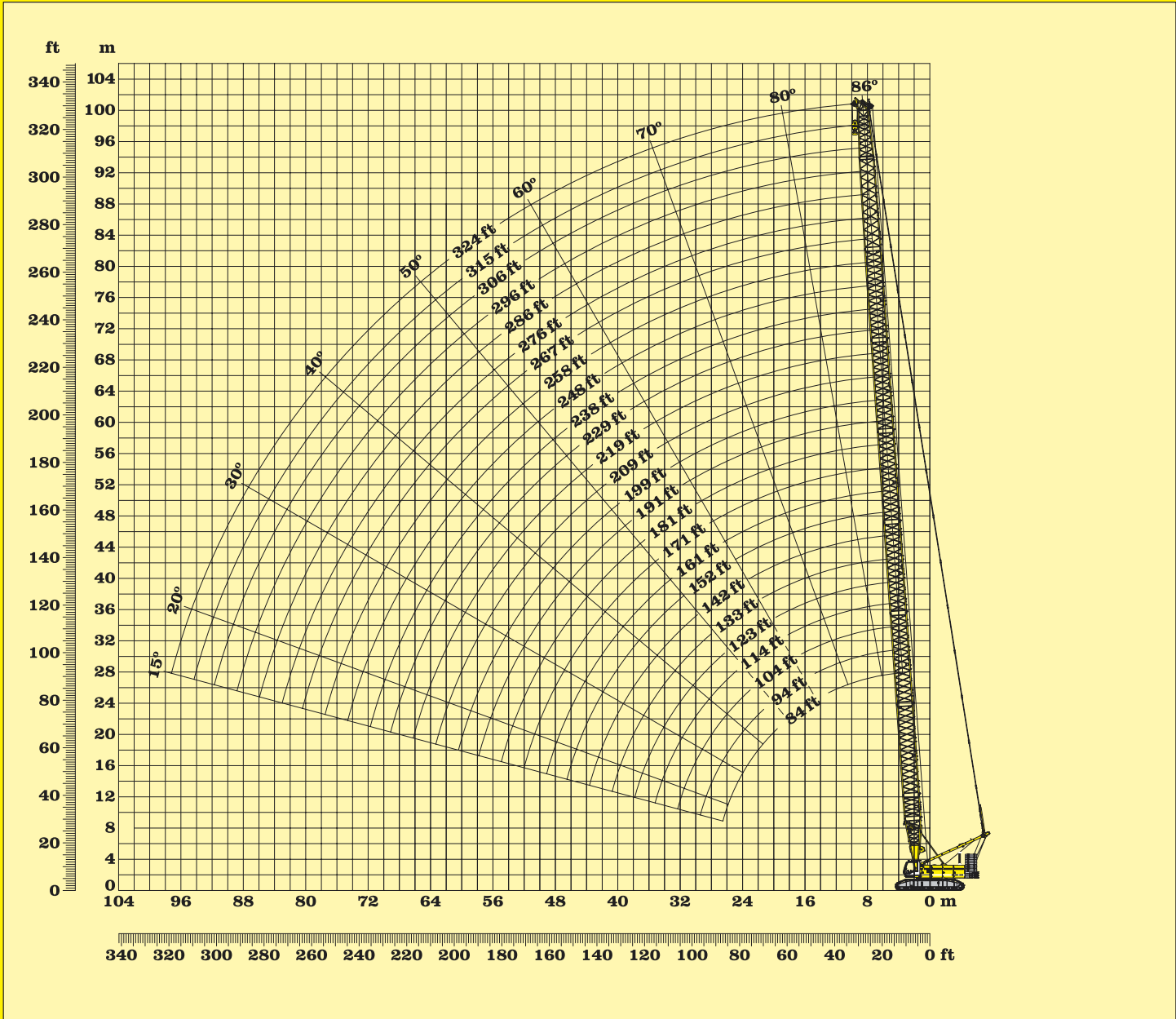

**L – boom configuration**

Configuration for boom lengths between 84 ft to 324 ft:

Length	Number of boom extensions																									
Boom foot (No. 2220.xx) 23 ft*	1	1	1	1	1	1	1	1	1	1	1	1	1	1	1	1	1	1	1	1	1					
Boom insert (No. 2220.xx) 10 ft*		1		1		1		1		1		1		1		1		1		1						
Boom insert (No. 2220.xx) 20 ft*			1	1		1	1		1	1		1	1		1	1		1	1		1					
Boom insert (No. 2220.xx) 38 ft*				1	1	1	1	2	2	2	2	3	3	3	3	4	4	4	4	5	5	5	5	6	6	
Tapered (No. 2220.xx / 2018.xx) 38 ft*	1	1	1	1	1	1	1	1	1	1	1	1	1	1	1	1	1	1	1	1	1	1	1	1	1	
Boom head (No. 2018.xx) 23 ft*	1	1	1	1	1	1	1	1	1	1	1	1	1	1	1	1	1	1	1	1	1	1	1	1	1	
Boom length in (ft)	84	94	104	114	123	133	142	152	161	171	181	191	199	209	219	229	238	248	258	267	276	286	296	306	315	324

\*Actual lengths of boom sections are metric (e.g. 3m, 6m, 11.7 m). The figures shown above are approximate conversions to feet.

**L – boom high reach 84 ft to 324 ft  
working range 86° - 15°**

**Capacities in 1000 lbs for l boom lengths from 84 ft to 324 ft – with 33.100 lbs winches:  
counterweight 188.500 lbs and 79.400 lbs carbody counterweight**

Radius (ft)	L – boom length in (ft)													Radius (ft)
	84 lbs	114 lbs	133 lbs	152 lbs	171 lbs	191 lbs	209 lbs	229 lbs	248 lbs	267 lbs	286 lbs	306 lbs	324 lbs	
16.8		308.6												16.8
20	308.6	308.6	308.2	293.0										20
25	299.5	289.0	299.0	277.5	248.9	228.0	198.2	172.3						25
30	250.1	262.6	234.9	233.5	239.3	216.3	195.5	171.0	149.1	121.8	104.7			30
35	231.7	201.0	205.5	198.8	179.4	195.4	185.0	167.9	145.4	120.5	103.4	83.8	72.1	35
40	196.4	180.9	169.0	173.0	170.3	152.7	147.4	147.4	141.3	119.2	101.3	82.1	70.5	40
45	178.2	165.8	152.1	142.5	144.8	147.1	137.2	132.9	120.4	113.7	92.7	80.9	69.2	45
50	149.3	144.0	141.8	133.3	119.0	118.9	123.0	119.1	113.4	107.3	90.8	79.1	67.9	50
55	135.9	135.4	120.3	120.9	114.5	109.9	111.0	111.2	108.1	102.1	89.2	77.4	60.4	55
60	121.2	120.6	115.1	112.0	108.8	102.5	100.8	100.3	92.1	95.7	87.9	76.0	59.3	60
65	109.1	108.6	108.4	104.3	100.7	93.9	88.0	84.0	85.0	87.4	84.8	74.9	58.4	65
70	98.4	93.8	93.8	93.6	88.1	87.8	85.6	79.8	78.8	80.0	77.8	71.2	57.6	70
75	90.6	90.2	88.5	89.2	84.5	82.4	80.0	76.3	73.5	73.5	71.5	60.4	54.9	75
80	83.3	82.9	82.7	81.9	81.4	77.6	74.9	71.8	69.2	67.9	58.7	57.4	52.5	80
85	76.8	76.6	76.4	75.6	75.1	73.5	70.3	67.4	63.0	61.9	57.0	54.6	50.2	85
90		71.1	70.9	70.1	69.6	68.8	61.8	59.0	59.6	59.4	55.6	52.2	48.2	90
95		64.6	63.7	63.4	60.5	62.6	61.0	56.9	56.5	56.0	53.4	50.1	46.4	95
100		61.9	61.6	61.0	58.6	59.3	58.9	55.0	53.6	52.8	50.3	48.0	44.9	100
105		58.0	57.9	57.1	56.6	55.7	55.1	53.5	51.1	49.8	47.4	45.2	43.3	105
110		54.5	54.4	53.7	53.1	52.3	51.6	50.6	48.8	47.1	44.7	42.5	40.8	110
120			48.3	47.6	47.1	46.3	45.6	44.6	43.9	42.6	40.0	37.9	36.2	120
130			43.2	42.6	42.1	41.2	40.6	39.6	38.9	37.9	36.2	33.9	28.7	130
140				38.3	37.9	37.0	36.3	35.4	34.6	33.6	31.0	30.4	27.3	140
150				34.6	34.2	33.4	30.8	31.9	29.4	27.7	27.8	27.7	26.2	150
170					28.2	27.5	26.9	25.9	25.2	24.2	22.5	21.6	20.4	170
190						22.7	22.2	21.3	20.5	19.5	18.4	16.8	15.4	190
205							19.3	18.4	17.6	16.6	15.2	13.9	12.4	205
215								16.7	15.8	14.6	13.3	12.0	10.7	215
225								14.8	14.0	12.9	11.5	10.3	9.0	225
245									10.5	9.9	8.6	7.2	6.0	245
265										6.8	5.9	4.9	3.4	265
280											3.9	3.6	2.3	280
295												2.2		295

Above lift chart is for reference only. For actual lift duty please refer to lift chart in operator’s cab or manual.

# Lift chart for L – boom configuration

**188.500 lbs counterweight and 79.400 lbs carbody counterweight**

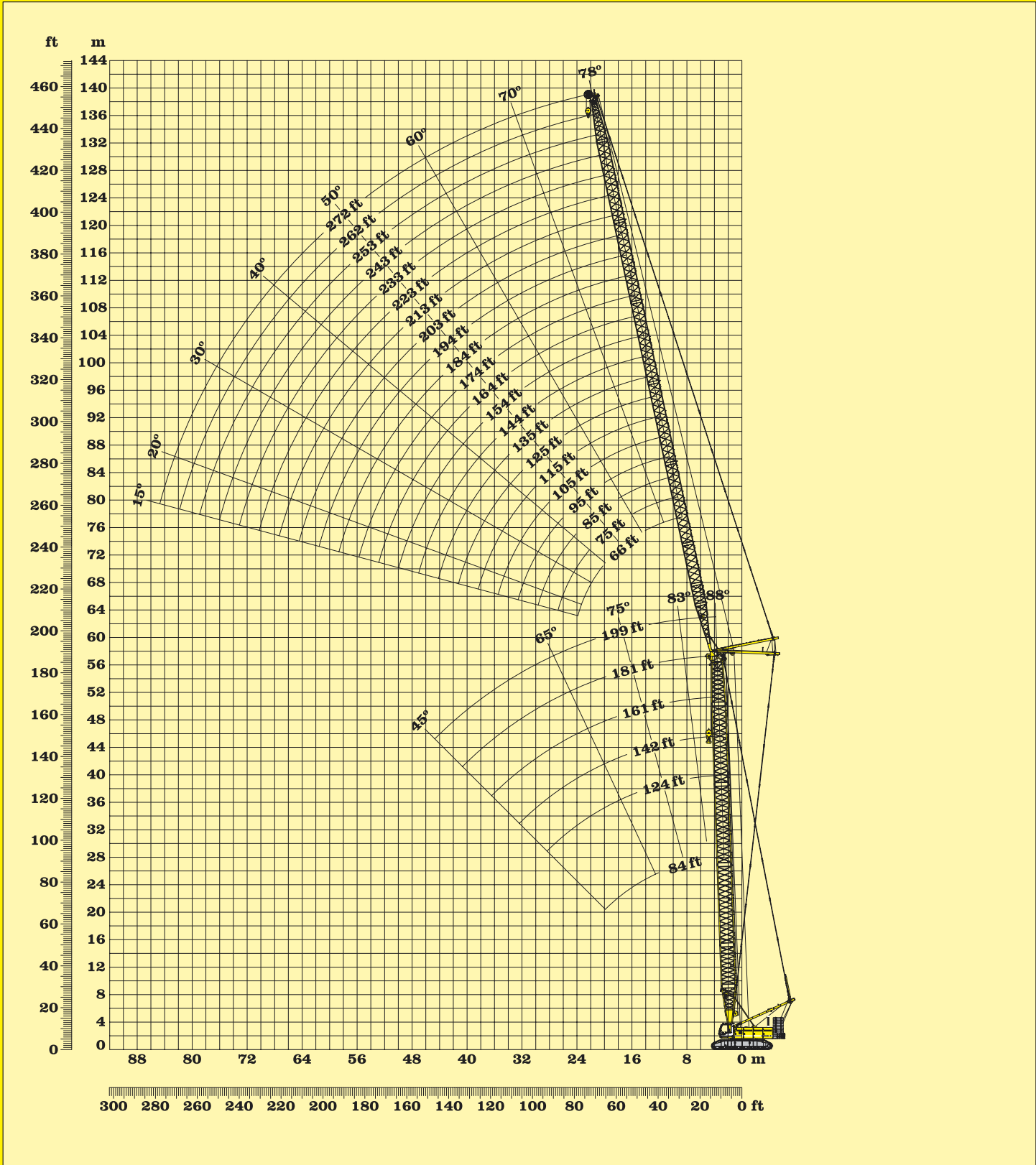

**Working range - luffing jib 78° - 15°  
main boom 88° - 45°**



### Main boom 84 ft

Radius in (ft)	Jib length (ft)								
	66 lbs	95 lbs	135 lbs	164 lbs	194 lbs	223 lbs	243 lbs	262 lbs	272 lbs
40	190.8								
50	158.7	139.1							
65	113.9	113.1	86.8						
70	103.5	103.1	83.4	72.3					
80	87.1	87.5	76.8	69.5	51.4				
90		75.8	69.9	66.7	49.1	39.3			
95		70.9	62.5	64.1	48.0	38.4	31.4		
100		66.6	60.5	63.1	47.0	37.7	31.0	25.1	
105		62.3	58.4	61.5	46.0	36.9	30.5	24.8	22.6
110		33.4	56.1	58.0	44.9	36.3	30.0	24.5	22.3
145			40.1	41.2	38.8	31.3	27.2	22.1	20.1
175				30.8	27.0	26.6	25.2	20.0	18.3
205					23.7	19.2	23.6	18.1	16.7
230						18.3	20.7	16.6	15.6
250							17.0	15.1	14.4
270								13.1	12.8
280									11.7

### Main boom 123 ft

Radius in (ft)	Jib length (ft)								
	66 lbs	95 lbs	135 lbs	164 lbs	194 lbs	223 lbs	243 lbs	262 lbs	272 lbs
44.7	163.6								
55	138.3	128.3							
65	112.0	111.3	83.4						
75	93.7	93.2	79.5	67.3					
85	80.3	80.0	74.2	64.4	48.1				
95		69.9	68.4	62.1	46.4	36.9			
100		65.6	62.2	60.9	45.5	36.1	29.0		
105		61.8	59.9	59.8	44.7	35.5	28.7	23.3	
110		58.4	57.6	57.0	43.8	34.8	28.4	23.3	21.1
150			39.3	38.7	37.7	26.3	24.5	20.9	19.0
180				20.9	19.9	19.4	16.9	19.3	17.5
205					17.7	15.6	14.7	17.0	16.1
235						13.7	12.4	12.9	13.7
255							11.7	11.7	12.1
275								11.0	11.0
285									10.2
295									

### Main boom 142 ft

Radius in (ft)	Jib length (ft)								
	66 lbs	95 lbs	135 lbs	164 lbs	194 lbs	223 lbs	243 lbs	262 lbs	272 lbs
47.1	163.6								
60	122.7	120.8							
70	101.2	100.6	80.2						
80	85.8	85.3	75.9	63.6					
85	79.6	79.2	73.6	62.6	46.6				
95		69.2	68.3	60.5	45.5	35.5			
100		65.0	63.1	59.4	44.7	35.2	28.0		
105		61.3	60.4	58.3	43.8	34.7	28.0	22.6	
110		57.9	57.1	56.4	43.0	34.1	27.7	22.5	20.4
115		54.8	54.1	53.4	42.2	33.5	27.5	22.4	20.3
155			22.8	36.7	35.9	22.4	22.6	20.3	18.4
180				18.2	17.5	16.7	14.1	18.8	17.1
210					14.6	13.9	12.4	15.7	15.3
240						11.8	11.1	11.0	12.6
255							10.5	10.4	11.3
275								9.9	10.2
285									9.4

### Main boom 161 ft

Radius in (ft)	Jib length (ft)								
	66 lbs	95 lbs	135 lbs	164 lbs	194 lbs	223 lbs	243 lbs	262 lbs	272 lbs
49.3	131.6								
60	121.5	112.8							
70	100.2	99.5	75.5						
80	85.0	84.5	72.8	59.4					
90		73.5	73.2	69.1	58.1	44.0			
100			62.3	63.4	56.2	42.7	33.6		
105			60.0	59.8	55.2	41.9	32.0	26.6	
110			57.3	56.5	54.1	41.2	31.6	26.4	19.4
115			54.2	53.5	52.8	40.5	31.0	26.1	21.4
120				28.0	50.7	50.1	39.8	28.7	25.9
155					36.1	36.3	35.0	16.3	22.2
185						15.3	15.2	14.0	12.6
215							12.4	12.0	11.1
240								10.4	10.1
260									9.5
280									7.9
290									7.6

### Main boom 181 ft

Radius in (ft)	Jib length (ft)								
	66 lbs	95 lbs	135 lbs	164 lbs	194 lbs	223 lbs	243 lbs	262 lbs	272 lbs
51.7	128.3								
65	108.7	98.6							
75	91.1	90.3	70.7						
85	78.1	77.5	67.7	54.9					
90	72.8	72.3	64.7	54.0	41.8				
95	32.6	67.7	63.4	53.1	41.6				
100		59.7	61.6	52.2	40.9	30.3			
105		55.5	59.0	51.2	40.3	30.3	25.4		
110		51.1	55.7	50.3	39.6	30.0	25.3	20.5	
120		46.3	50.1	47.8	38.3	28.7	24.7	20.4	18.5
160			17.2	18.0	16.9	16.4	21.7	18.5	16.8
190				13.4	13.0	12.5	18.3	12.8	13.9
215					11.5	10.5	14.7	10.2	11.5
245						9.3	11.0	8.6	9.2
265							9.1	8.1	8.0
285								7.4	7.4
295									6.9

### Main boom 199 ft

Radius in (ft)	Jib length (ft)								
	66 lbs	95 lbs	135 lbs	164 lbs					
54	99.2								
65	97.9	84.3							
75	90.0	79.7	60.5						
85	77.2	74.4	58.6	47.8					
95	67.3	66.4	56.0	46.5					
110		48.1	51.1	43.9					
120		42.7	47.4	42.1					
130			41.7	40.1					
140			35.3	38.0					
150			17.4	34.2					
160			15.7	16.1					
170				14.4					
180				13.5					
190				12.2					

Capacities in 1000 lbs with luffing jib (No. 1916.xx) 188,500 lbs counterweight + 79,400 lbs carbody counterweight.  
 Above lift chart is for reference only. For actual lift duty please refer to lift chart in operator's cab or manual.

# Lift chart - luffing jib - main boom angle 83°

### Main boom 84 ft

Radius in (ft)	Jib length (ft)								
	66 lbs	95 lbs	135 lbs	164 lbs	194 lbs	223 lbs	243 lbs	262 lbs	272 lbs
64.4	109.7								
75	90.8	90.4							
90	72.6	72.3	71.3						
100	63.8	63.6	62.7						
105		60.0	59.0	58.3					
115		53.7	52.8	52.1	45.1				
120		50.9	50.1	49.4	44.7				
130			45.4	44.7	43.0	34.4			
140			41.4	40.8	39.9	33.4	28.0		
145			39.6	39.0	38.1	31.8	27.6	22.3	
155			36.4	35.8	35.0	30.9	26.9	21.9	19.8
160			34.9	34.4	33.5	30.5	26.5	21.6	19.5
190				27.4	26.7	26.0	24.7	19.7	18.0
215					22.4	21.8	21.3	18.2	16.7
245						17.9	17.4	16.4	15.4
265							15.3	14.8	14.4
285								13.0	12.7
295									11.9

### Main boom 123 ft

Radius in (ft)	Jib length (ft)								
	66 lbs	95 lbs	135 lbs	164 lbs	194 lbs	223 lbs	243 lbs	262 lbs	272 lbs
70.1	95.0								
85	75.1	74.2							
90	70.0	69.2							
100	61.5	60.9	59.8						
115		51.4	50.3	49.5					
125		46.3	45.4	44.6	42.5				
130		44.1	43.2	42.5	41.5				
140			39.4	38.7	37.7	31.2			
150			36.1	35.4	34.5	30.6	26.3		
155			34.7	34.0	30.8	30.2	26.0	20.8	
165			32.0	31.4	28.3	29.3	25.4	20.6	18.6
170			30.8	30.2	27.3	28.5	25.0	20.4	18.3
200				24.2	23.4	22.7	22.2	18.9	17.1
225					19.7	17.5	18.6	17.5	16.0
255						15.6	15.2	14.6	14.3
275							13.3	12.8	12.5
295								11.2	10.9
305									10.2

### Main boom 142 ft

Radius in (ft)	Jib length (ft)								
	66 lbs	95 lbs	135 lbs	164 lbs	194 lbs	223 lbs	243 lbs	262 lbs	272 lbs
75.2	84.9								
90	68.2	67.3							
105	56.5	55.8	54.6						
120		47.4	46.3	45.5					
130		42.9	42.0	41.2	40.1				
135		40.9	40.0	39.2	38.2				
145			36.6	35.8	34.8	30.2			
155			33.6	32.6	31.5	29.7	25.4		
160			32.3	31.6	30.3	29.3	25.3	20.2	
170			29.6	29.2	27.8	27.4	24.6	20.0	18.0
175			27.8	28.1	26.7	26.4	24.2	19.8	17.8
200				23.1	22.6	21.8	21.3	18.7	16.9
230					18.4	17.2	17.2	16.6	15.6
260						14.5	14.0	13.5	13.1
275							12.7	12.1	11.8
295								10.6	10.3
305									9.6

### Main boom 161 ft

Radius in (ft)	Jib length (ft)								
	66 lbs	95 lbs	135 lbs	164 lbs	194 lbs	223 lbs	243 lbs	262 lbs	272 lbs
80.1	76.6								
95	62.2	61.3							
110	51.9	51.3	50.0						
125		43.8	42.7	41.9					
135		39.8	38.8	38.0	36.9				
140		38.0	37.0	36.2	35.2				
150			33.9	32.2	31.8	28.4			
155			31.3	31.8	30.8	27.9	24.3		
165			29.6	29.3	28.3	26.9	24.1	19.2	
175			26.4	26.9	25.4	25.3	23.6	19.1	17.2
180			24.3	25.3	24.1	24.4	23.3	18.9	17.0
205				19.7	19.8	20.2	19.6	17.6	16.1
235					16.0	14.4	15.8	15.2	14.8
265						13.1	12.4	12.3	12.0
285							11.2	10.7	10.4
305								9.3	9.0
310									8.7

### Main boom 181 ft

Radius in (ft)	Jib length (ft)								
	66 lbs	95 lbs	135 lbs	164 lbs	194 lbs	223 lbs	243 lbs	262 lbs	272 lbs
85.2	68.8								
100	56.6	55.6							
115	47.6	46.9	45.6						
130		40.3	39.1	38.3					
140		36.7	35.6	34.8	33.7				
145		35.1	34.1	32.7	32.2				
155			30.5	30.4	29.5	27.2			
165			27.9	27.8	27.1	26.2	22.9		
170			26.6	26.6	26.0	25.2	22.8	18.2	
180			23.7	24.1	22.7	23.2	22.5	18.2	16.3
185			21.8	22.7	21.2	22.3	21.7	18.1	16.2
210				17.9	17.9	16.8	17.9	16.9	15.5
240					14.3	13.2	14.4	13.8	13.2
270						11.7	11.2	11.1	10.8
285							10.4	10.0	9.7
305								8.6	8.3
315									7.7

### Main boom 199 ft

Radius in (ft)	Jib length (ft)								
	66 lbs	95 lbs	135 lbs	164 lbs					
90	62.2								
105	51.6	50.6							
110	48.7	47.8							
120	43.7	42.9	41.6						
135		37.1	35.9	35.0					
150		28.1	30.1	28.6					
160			27.3	26.5					
170			24.1	24.5					
180			21.6	22.4					
190			18.7	20.0					
200				18.0					
210				16.7					
215				15.9					

Capacities in 1000 lbs with luffing jib (No. 1916.xx) 188.500 lbs counterweight + 79.400 lbs carbody counterweight.  
Above lift chart is for reference only. For actual lift duty please refer to lift chart in operator's cab or manual.

# Lift chart - luffing jib - main boom angle 75°

### Main boom 84 ft

Radius in (ft)	Jib length (ft)								
	66 lbs	95 lbs	135 lbs	164 lbs	194 lbs	223 lbs	243 lbs	262 lbs	272 lbs
84	75.1								
90	69.0								
105	57.1	56.5							
125		45.6	44.6						
135		33.4	40.6						
145			37.1	36.3					
160			32.7	32.1	31.1				
170			30.2	29.6	28.7				
175				28.5	27.6	26.7			
190				25.5	24.6	23.9	23.3		
200				23.8	22.9	22.2	21.6	19.0	
210					21.4	20.6	20.1	18.7	17.0
230					18.7	18.0	17.5	16.9	16.2
255						15.2	14.8	14.2	13.9
275							12.9	12.4	12.1
295								10.8	10.5
305									9.8

### Main boom 123 ft

Radius in (ft)	Jib length (ft)								
	66 lbs	95 lbs	135 lbs	164 lbs	194 lbs	223 lbs	243 lbs	262 lbs	272 lbs
100.2	56.1								
110	50.0								
120	44.9	44.1							
140		36.4	35.3						
150		33.4	32.3						
160			29.8	29.0					
175			26.5	25.7	24.6				
190			23.6	23.0	21.9				
195				22.2	21.1	20.3			
205				20.6	19.7	18.9	18.3		
215				19.3	18.3	17.5	17.0	16.3	
225					17.1	16.3	15.8	15.1	14.7
245					14.9	14.2	13.7	13.0	12.7
275						11.6	11.1	10.5	10.1
295							9.6	9.1	8.7
310								8.1	7.8
320									7.2

### Main boom 142 ft

Radius in (ft)	Jib length (ft)								
	66 lbs	95 lbs	135 lbs	164 lbs	194 lbs	223 lbs	243 lbs	262 lbs	272 lbs
108.5	48.4								
110	47.6								
120	42.7								
130	38.6	37.8							
150		31.6	30.4						
160		29.0	28.0						
170			25.8	25.0					
185			23.0	22.3	21.2				
200			20.6	19.9	18.9	18.0			
215				17.9	16.9	16.1	15.5		
225				16.7	15.8	15.0	14.4	13.7	
235					14.7	13.9	13.4	12.7	12.3
255					12.8	12.1	11.5	11.3	10.5
285						9.8	9.3	8.7	8.3
305							8.0	7.4	7.1
320								6.6	6.2
330									5.7

### Main boom 161 ft

Radius in (ft)	Jib length (ft)								
	66 lbs	95 lbs	135 lbs	164 lbs	194 lbs	223 lbs	243 lbs	262 lbs	272 lbs
116.4	42.1								
135	34.9	34.0							
140	33.4	32.5							
160		27.4	26.2						
170		25.2	24.2						
175			23.2	22.4					
190			20.8	19.9	18.7				
205			18.6	17.9	16.8				
210				17.2	16.2	15.3			
220				16.1	15.0	14.2	13.6		
230				15.0	14.0	13.1	12.5	11.5	
235				14.5	13.5	12.7	12.1	11.1	10.4
245					12.6	11.8	11.2	10.3	9.6
265					10.9	10.2	9.6	8.8	8.2
290						8.5	7.9	7.3	6.7
310							6.8	6.2	5.7
330								5.1	4.8
340									4.3

### Main boom 181 ft

Radius in (ft)	Jib length (ft)								
	66 lbs	95 lbs	135 lbs	164 lbs	194 lbs	223 lbs	243 lbs	262 lbs	272 lbs
124.7	36.1								
145	29.6	28.9							
165		24.4	23.1						
175		22.5	21.4						
185			19.8	18.9					
200			17.7	16.9	15.7				
215			15.8	15.1	14.0				
220				14.6	13.5	12.4			
230				13.6	12.5	11.5	10.5		
240				12.6	11.6	10.7	9.7	8.6	
250					10.8	10.0	9.0	7.9	7.2
270					9.3	8.5	7.7	6.6	6.0
300						6.7	6.1	5.1	4.5
320							5.2	4.3	3.7
335								3.7	3.1
345									2.8

### Main boom 199 ft

Radius in (ft)	Jib length (ft)								
	66 lbs	95 lbs	135 lbs	164 lbs					
132.6	30.9								
150	26.6	25.4							
155	25.4	24.5							
175		20.8	19.5						
180		20.0	18.8						
190			17.4	16.4					
210			15.0	14.1					
220			13.9	13.1					
230				12.2					
240				11.3					
250				10.5					

Capacities in 1000 lbs with luffing jib (No. 1916.xx) 188,500 lbs counterweight + 79,400 lbs carbody counterweight.  
 Above lift chart is for reference only. For actual lift duty please refer to lift chart in operator's cab or manual.

# Lift chart - luffing jib - main boom angle 65°

### Main boom 84 ft

Radius (ft)	Jib length (ft)								
	66	95	135	164	194	223	243	262	272
	lbs	lbs	lbs	lbs	lbs	lbs	lbs	lbs	lbs
123.7	42.0								
130	39.4								
150		32.3							
160		29.7							
185			23.6						
200			21.1						
205				19.7					
225				17.2					
230					15.7				
255					13.2	12.5			
270						11.3	10.8		
285						10.2	9.7	9.0	
300							8.7	8.1	7.7
305								7.8	7.4
320								6.9	6.6
330									6.0

### Main boom 123 ft

Radius (ft)	Jib length (ft)								
	66	95	135	164	194	223	243	262	272
	lbs	lbs	lbs	lbs	lbs	lbs	lbs	lbs	lbs
150.8	27.6								
160	25.7								
175		21.9							
185		20.4							
210			15.9						
225			14.3						
235				12.6					
255				10.9					
260					9.6				
280					8.2	7.4			
300						6.3	5.7		
310						5.8	5.2		
315							5.0	4.3	
330							4.3	3.7	3.3
340								2.8	2.9
355									2.3

### Main boom 142 ft

Radius (ft)	Jib length (ft)							
	66	95	135	164	194	223	243	
	lbs	lbs	lbs	lbs	lbs	lbs	lbs	
164.8	22.1							
170	21.2							
190		17.2						
200		16.0						
225			12.2					
235			11.3					
250				9.4				
265				8.4				
270					7.0			
295					5.6	4.8		
310						4.1	3.4	
320						3.7	3.1	
340							2.4	

### Main boom 161 ft

Radius (ft)	Jib length (ft)						
	66	95	135	164	194	223	
	lbs	lbs	lbs	lbs	lbs	lbs	
178	17.3						
185	16.5						
205		13.2					
215		12.2					
235			9.3				
250			8.3				
260				6.9			
280				5.8			
285					4.4		
310					3.4	2.2	

Capacities in 1000 lbs with luffing jib (No. 1916.xx) 188,500 lbs counterweight + 79,400 lbs carbody counterweight.

Above lift chart is for reference only. For actual lift duty please refer to lift chart in operator's cab or manual.

### Boom configuration for main boom lengths (84 ft to 199 ft) – see table 1 on page 8

#### Jib configuration (No. 1916.xx)

	Length	Number of luffing jib extensions																				
		1	1	1	1	1	1	1	1	1	1	1	1	1	1	1	1	1	1	1	1	
Luffing jib foot	23 ft	1	1	1	1	1	1	1	1	1	1	1	1	1	1	1	1	1	1	1	1	
Luffing jib insert	10 ft*				1			1			1			1			1			1		
Luffing jib insert	20 ft*	1	1					1	1				1	1			1	1			1	
Luffing jib insert	38 ft*				1	1	1	1	2	2	2	2	3	3	3	3	4	4	4	4	5	
Luffing jib head	23 ft	1	1	1	1	1	1	1	1	1	1	1	1	1	1	1	1	1	1	1	1	
Luffing jib length in ft		66	75	85	95	105	115	125	135	144	154	164	174	184	194	203	213	223	233	243		
																				253	262	272

\*Actual lengths of boom sections are metric (e.g. 3m, 6m, 11.7m). The figures shown above are approximate conversions to feet.

# Lift chart - luffing jib - main boom angle 45°

**188.500 lbs counterweight and 79.400 lbs carbody counterweight**

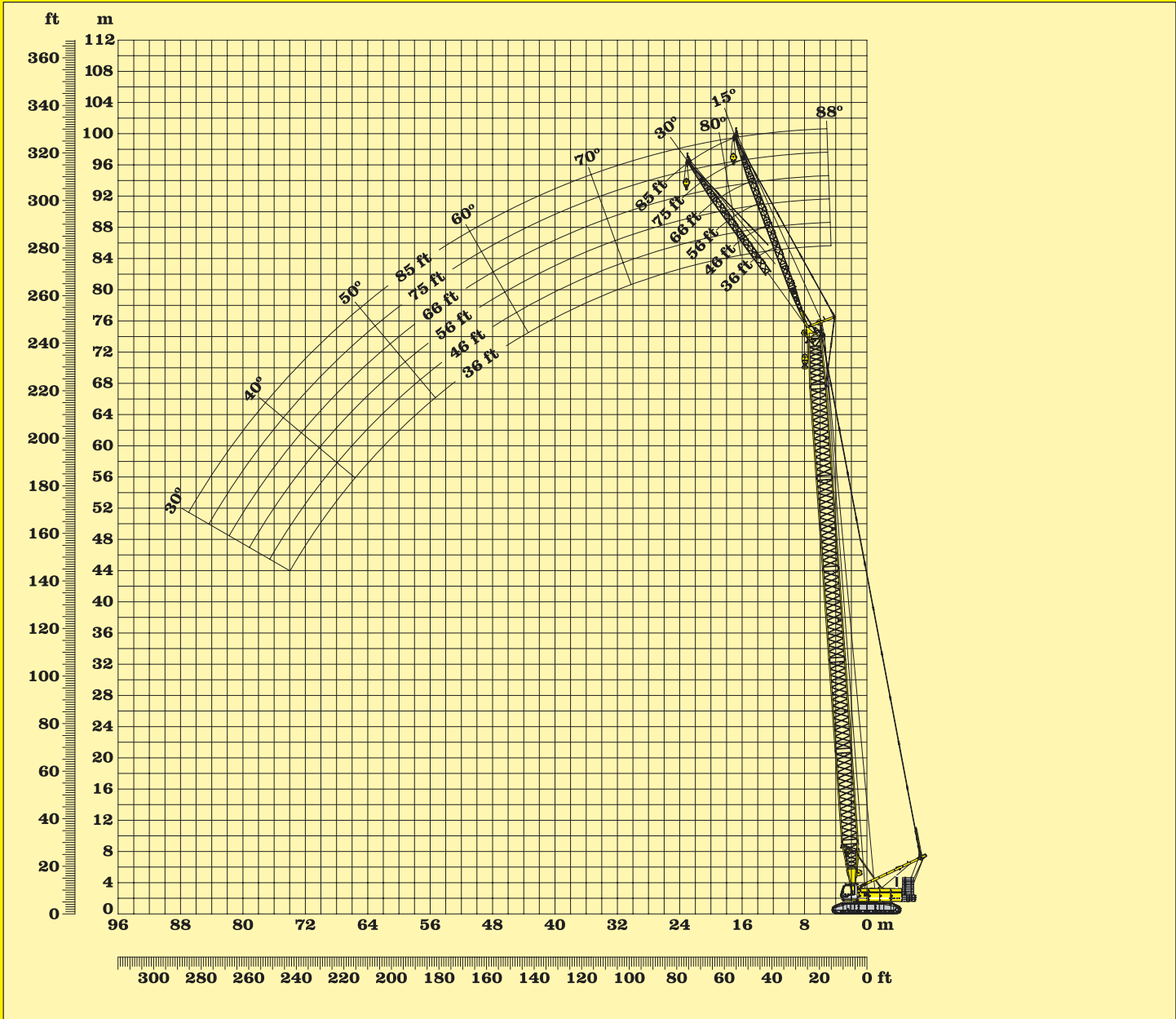

**Boom configuration for boom lengths between 85 ft to 258 ft – see table 1 on page 8**

**Fixed jib configuration (No. 1008.xx)**

Configuration for jib lengths between 36 ft to 85 ft:							
	Length	Number of boom extensions					
Fixed jib foot	18 ft	1	1	1	1	1	1
Fixed jib insert	10 ft*		1		1		1
Fixed jib insert	20 ft*			1	1	2	2
Fixed jib head	18 ft	1	1	1	1	1	1
Fixed jib length in feet		36	46	56	66	75	85

\*Actual lengths of boom sections are metric (e.g. 3m, 6m). The figures shown above are approximate conversions to feet.

**Working range - fixed jib 15° and 30°  
main boom 88° - 30°**

### Main boom 84 ft

Radius (ft)	Fixed jib length (ft)					
	36 lbs	46 lbs	56 lbs	66 lbs	76 lbs	85 lbs
19.8	80.8					
25	81.1	80.9				
30	81.2	80.9	80.9			
35	81.2	81.0	81.1	75.8		
40	81.2	81.0	80.3	70.7	60.2	51.3
45	81.2	81.1	74.8	65.8	58.0	49.4
110	52.6	45.4	38.1	32.3	31.2	27.7
120		42.2	35.7	31.6	28.7	25.7
130			33.4	30.1	26.7	23.8
140				28.3	25.1	22.3
150					23.6	21.1
160						19.9

### Main boom 123 ft

Radius (ft)	Fixed jib length (ft)					
	36 lbs	46 lbs	56 lbs	66 lbs	76 lbs	85 lbs
21.1	80.8					
25	81.0	81.2				
30	81.0	81.2	80.8			
35	80.9	81.2	81.0	75.5		
40	80.9	81.2	81.1	73.1	59.5	
45	80.9	81.1	81.0	68.8	58.0	49.1
145	33.6	34.3	35.0	31.6	28.1	24.9
155		30.9	31.6	30.6	26.6	23.5
165			28.5	29.0	25.3	22.3
175				26.2	24.2	21.3
185					23.2	20.4
195						19.6

### Main boom 142 ft

Radius (ft)	Fixed jib length (ft)					
	36 lbs	46 lbs	56 lbs	66 lbs	76 lbs	85 lbs
21.8	81.2					
25	81.2					
30	81.1	81.2	81.2			
35	80.9	81.2	81.0	75.1		
40	80.9	81.2	81.0	73.1	59.1	
45	80.9	81.2	81.0	69.6	57.9	48.9
165	26.3	27.0	27.6	28.1	26.9	23.6
175		24.2	24.9	25.4	25.7	22.6
185			22.4	22.9	23.5	21.7
195				20.7	21.3	20.8
205					19.2	19.7
210						18.7

### Main boom 161 ft

Radius (ft)	Fixed jib length (ft)					
	36 lbs	46 lbs	56 lbs	66 lbs	76 lbs	85 lbs
22.5	81.2					
25	87.3					
30	81.1	80.9				
35	81.1	80.9	80.9	73.5		
40	81.2	81.0	80.9	72.1	58.2	
45	81.1	81.2	80.3	69.9	57.0	48.5
180	21.7	22.3	22.9	23.4	23.9	23.3
190		20.0	20.6	21.1	21.6	22.0
200			18.5	19.0	19.5	19.9
205				18.1	18.6	19.0
215					16.8	17.2
225						15.5

### Main boom 181 ft

Radius (ft)	Fixed jib length (ft)					
	36 lbs	46 lbs	56 lbs	66 lbs	76 lbs	85 lbs
23.1	81.0					
25	80.9					
30	80.9	80.9				
35	81.0	81.1	81.1	72.0		
40	81.1	81.2	81.2	71.0	57.3	
45	81.2	81.2	80.1	69.7	56.3	47.9
200	16.5	17.0	17.6	18.1	18.6	19.0
205		16.1	16.7	17.2	17.7	18.1
215			14.9	15.4	15.9	16.3
225				13.7	14.2	14.6
235					12.7	13.1
245						11.7

### Main boom 199 ft

Radius (ft)	Fixed jib length (ft)					
	36 lbs	46 lbs	56 lbs	66 lbs	76 lbs	85 lbs
23.8	81.2					
25	81.2					
30	80.9	81.1				
35	80.8	81.0	75.2			
40	80.9	81.0	75.3	67.2	55.7	
45	81.0	81.0	75.5	67.3	55.2	46.9
215	13.0	13.6	14.1	14.6	15.1	15.5
225		11.9	12.5	13.0	13.5	13.8
235			11.0	11.5	12.0	12.3
245				10.1	10.6	10.9
255					9.3	9.6
265						8.4

### Main boom 219 ft

Radius (ft)	Fixed jib length (ft)					
	36 lbs	46 lbs	56 lbs	66 lbs	76 lbs	85 lbs
24.5	81.2					
30	81.0	75.9				
35	80.8	76.5	69.8			
40	80.9	77.4	70.0	59.4		
45	81.0	77.4	70.2	60.0	53.9	46.1
50	81.1	77.4	70.5	60.5	53.3	45.5
230	9.7	10.3	10.8	11.3	11.8	12.1
240		8.8	9.4	9.8	10.3	10.7
250			8.1	8.5	9.0	9.4
260				7.3	7.7	8.1
270					6.6	7.0
280						5.9

### Main boom 238 ft

Radius (ft)	Fixed jib length (ft)					
	36 lbs	46 lbs	56 lbs	66 lbs	76 lbs	85 lbs
25.1	76.2					
30	76.0	69.6				
35	75.5	69.7	59.2			
40	75.6	69.9	59.6	54.9		
45	75.9	69.9	60.2	54.9	49.7	44.4
50	76.2	69.8	60.3	54.9	49.5	44.1
245	6.9	7.4	7.9	8.4	8.8	9.2
255		6.1	6.7	7.1	7.6	7.9
265			5.5	5.9	6.4	6.7
275				4.8	5.3	5.6
285					4.2	4.6
295						3.6

### Main boom 258 ft

Radius (ft)	Fixed jib length (ft)					
	36 lbs	46 lbs	56 lbs			
25.8	70.6					
30	70.4	61.3				
35	69.6	61.0	55.7			
40	69.4	60.5	55.7			
45	69.5	60.4	55.7			
50	69.7	60.5	55.8			
265	3.5	4.0	4.5			
275		2.9	3.5			
285			2.4			
290						
295						
300						

Capacities in 1000 lbs with fixed jib (No. 1008.xx) 188.500 lbs counterweight and 79.400 lbs carbody counterweight.  
Above lift chart is for reference only. For actual lift duty please refer to lift chart in operator's cab or manual.

# Lift chart - fixed jib - offset 15°

### Main boom 84 ft

Radius (ft)	Fixed jib length (ft)					
	36 lbs	46 lbs	56 lbs	66 lbs	76 lbs	85 lbs
28.5	81.2					
35	81.2	67.3				
45	74.5	61.0	50.8			
50	70.6	57.1	47.6	41.2		
55	65.2	54.3	45.1	38.9	34.5	
60	64.4	51.4	42.8	37.1	33.3	31.6
115	33.4	35.1	30.2	25.6	22.3	19.8
125		34.0	29.0	24.3	21.2	18.7
135			28.1	23.4	20.1	17.8
145				22.8	19.5	16.9
155					19.1	16.4
165						16.1

### Main boom 123 ft

Radius (ft)	Fixed jib length (ft)					
	36 lbs	46 lbs	56 lbs	66 lbs	76 lbs	85 lbs
29.8	81.1					
40	80.9	65.9				
45	79.6	63.1	51.6			
50	75.5	60.4	49.3	41.9		
55	72.3	57.5	47.1	40.2	35.1	
65	65.2	53.2	43.3	37.0	33.5	30.5
150	32.1	33.0	29.1	24.2	20.8	18.2
160		29.5	28.5	23.5	20.1	17.4
170			27.2	23.1	19.6	16.8
180				22.7	19.2	16.4
190					19.0	16.2
200						16.0

### Main boom 142 ft

Radius (ft)	Fixed jib length (ft)					
	36 lbs	46 lbs	56 lbs	66 lbs	76 lbs	85 lbs
30.5	81.2					
40	80.9	66.0				
45	80.5	64.2	52.0			
50	77.6	61.2	49.9	42.2		
55	74.2	58.9	47.7	40.5	35.0	
65	68.8	56.4	44.3	37.8	33.2	30.7
165	26.5	27.3	28.1	24.0	20.5	17.9
175		24.4	25.3	23.5	19.9	17.3
185			22.6	23.1	19.5	16.8
195				20.9	19.3	16.5
205					19.0	16.3
215						16.1

### Main boom 161 ft

Radius (ft)	Fixed jib length (ft)					
	36 lbs	46 lbs	56 lbs	66 lbs	76 lbs	85 lbs
31.2	80.9					
40	80.7	66.1				
45	80.3	65.0	52.6			
50	79.5	62.1	50.5	42.1		
60	73.2	57.7	46.7	39.3	34.0	
65	71.0	55.6	45.2	37.9	33.4	30.9
180	21.9	22.6	23.4	23.8	20.3	17.6
190		20.2	21.0	21.6	19.8	17.1
200			18.8	19.4	19.5	16.7
210				17.3	18.0	16.4
220					16.1	16.3
230						14.9

### Main boom 181 ft

Radius (ft)	Fixed jib length (ft)					
	36 lbs	46 lbs	56 lbs	66 lbs	76 lbs	85 lbs
31.9	81.0					
40	81.2	66.4				
45	80.4	65.1	52.2			
55	77.8	60.7	48.8	40.9		
60	74.8	58.9	47.1	39.7	34.2	
65	72.4	56.7	45.9	38.3	33.4	30.1
200	16.6	17.3	18.0	18.7	19.3	17.2
205		16.3	17.0	17.6	18.3	17.0
215			15.1	15.7	16.4	16.6
225				13.9	14.6	15.1
235					12.9	13.5
245						11.9

### Main boom 199 ft

Radius (ft)	Fixed jib length (ft)					
	36 lbs	46 lbs	56 lbs	66 lbs	76 lbs	85 lbs
32.5	79.8					
40	79.9	64.7				
45	79.7	64.5	52.0			
55	79.2	61.3	49.4	41.1		
60	76.3	59.6	47.6	40.0	34.5	
65	73.8	57.8	46.3	38.7	33.4	27.8
215	13.2	13.8	14.5	15.1	15.7	16.3
225		12.1	12.8	13.4	14.0	14.5
235			11.2	11.8	12.4	12.9
245				10.2	10.9	11.4
255					9.4	10.0
265						8.6

### Main boom 219 ft

Radius (ft)	Fixed jib length (ft)					
	36 lbs	46 lbs	56 lbs	66 lbs	76 lbs	85 lbs
33.2	74.3					
40	74.3	60.3				
50	74.7	61.4	51.0			
55	75.2	60.3	49.6	41.3		
60	74.9	59.5	48.1	40.1	34.5	
65	73.2	58.7	46.7	39.0	33.5	25.7
230	9.9	10.5	11.2	11.8	12.4	12.9
240		9.0	9.7	10.2	10.8	11.4
250			8.3	8.8	9.4	9.9
260				7.5	8.1	8.6
270					6.8	7.3
280						6.1

### Main boom 238 ft

Radius (ft)	Fixed jib length (ft)					
	36 lbs	46 lbs	56 lbs	66 lbs	76 lbs	85 lbs
33.8	67.3					
40	67.4	54.9				
50	67.8	55.7	51.2			
55	68.0	56.0	49.7	41.3		
60	68.4	56.1	48.5	40.2	34.5	
65	68.5	56.2	47.1	39.3	33.7	25.2
245	7.1	7.6	8.3	8.8	9.4	10.0
255		6.3	7.0	7.5	8.1	8.6
265			5.7	6.2	6.8	7.3
275				5.0	5.6	6.1
285					4.4	4.9
295						3.8

### Main boom 258 ft

Radius (ft)	Fixed jib length (ft)					
	36 lbs	46 lbs	56 lbs			
34.5	57.8					
45	57.9	51.9				
50	57.9	51.8	48.4			
65	58.1	51.8	47.1			
75	58.2	51.9	45.1			
85	58.3	52.0	43.4			
235	7.6	8.2	8.9			
245	6.2	6.8	7.4			
255	4.9	5.5	6.1			
265	3.7	4.2	4.9			
275		3.1	3.7			
285			2.6			

Capacities in 1000 lbs with fixed jib (No. 1008.xx) 188,500 lbs counterweight and 79,400 lbs carbody counterweight. Above lift chart is for reference only. For actual lift duty please refer to lift chart in operator's cab or manual.

# Lift chart - fixed jib - offset 30°



**MANUFACTURER:**  
**LIEBHERR-WERK NENZING GMBH,**  
P.O. Box 10, A-6710 Nenzing / Austria / Europe  
Tel. (01143) 5525 - 606 - 473,  
Fax (01143) 5525 - 606 - 499  
crawler.crane@lwn.liebherr.com  
www.liebherr.com

**US SALES:**  
**LIEBHERR NENZING CRANE CO.**  
1400 East North Belt, Suite 160  
77032 Houston, Texas  
Tel. (281) 219-7129 / Fax: (281) 219-7134  
crawler.crane@lnc.liebherr.com

**LOCAL DEALER:**