

GMK5250L

Product Guide

ASME B30.5

Imperial 85%



Features

- 250 t (300 USt) capacity
- 70 m (230 ft) seven-section main boom
- 21 m (69 ft) swingaway with jib and/or boom inserts.
- Maximum 37 m (121 ft) length and up to 50° offset.
- VIAB turbo retarder clutch
- Single engine design - less fuel consumption

GROVE GMK5250L

The GMK5250L puts power and performance to work for you with high capacities on a five-axle all-terrain crane and 230 ft main boom.

Features

- > The Grove GMK5250L is the first all-terrain crane to utilize a VIAB turbo clutch module, which is used by a number of heavy duty trucks. It enables wear-free starting and breaking, avoids overheating and burning, and reduces fuel consumption to a minimum; adding substantial fuel savings of approximately 30 % compared with its predecessor, the GMK5275. VIAB is a turbo coupling and integrated retarder all-in-one, which means less weight and less space, and it comes as standard on the new Grove crane.
- > Logistic benefits due to interchangeable counterweight slabs and self-rigging auxiliary hoist. Once on the job site, the crane can be moved while carrying its full counterweight of 80 t (176,300 lb), and its ability to travel in this configuration saves valuable time on the job that would otherwise be taken up with installing and removing counterweight sections. Besides this some of the counterweight slabs are interchangeable with those of the GMK6300L. The self-rigging auxiliary hoist eliminates the need for an assist crane during on-site rigging.
- > Boosting overall reach is a 21,3 m (69 ft) hydraulic swing-away jib, which can be extended with either an 8 m (26 ft) boom extension, two 8 m (26 ft) jib inserts, or a combination of both for a total possible jib length of 121 ft. For optimum usage, the full jib can be also operated while the crane is working with its full 70 m (230 ft) boom length extended. Another beneficial feature of the jib is its ability to offer increased offset of up to 50° compared to a typical 40° offset on other Grove cranes in its class; plus there is an optional integrated heavy duty jib available.

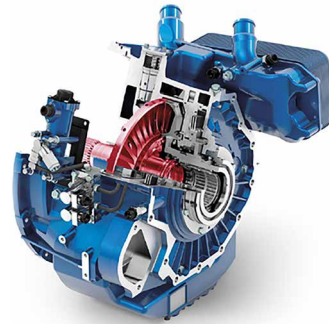

CraneSTAR

- > **CraneSTAR is an exclusive and innovative crane asset management system**

that helps improve your profitability and reduce costs by remotely monitoring critical crane data. Visit www.cranestar.com for more information.

Jobsite benefits

- Five outrigger positions provide ultimate flexibility for job sites with the ability to position the crane in tighter spaces.
- Mercedes engine and transmission with VIAB turbo clutch for premium maneuverability, optimized fuel consumption and powerful integrated retarder.
- Jobsite movement with full counterweight saves setup time.
- The GMK5250L is designed with a self-rigging auxiliary hoist, saving time and costs associated with operating an assist crane.
- Available swingaway configurations and extensions provide excellent flexibility and reach with up to 37,3 m (121 ft) and a 50° offset to reach over obstacles.
- Higher utilization with load charts usually offered by six-axle cranes.

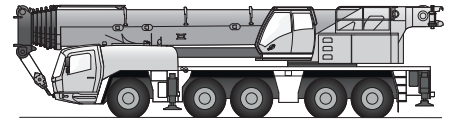

Manitowoc Crane Care when you need it.

The assurance of the world's most advanced crane service and support to get you back to work fast.



Manitowoc Finance helps you get right to work generating profits for your business.

Financial tools that help you capitalize on opportunity with solutions that fit your needs.

Contents

- Dimensions** _____ **5**
- Weights** _____ **6**
- Data** _____ **8**
- Dimensions** _____ **9**
 - Counterweight _____ 9
 - Auxiliary hoist _____ 9
 - Hose reel _____ 10
 - Jib combinations _____ 11
 - Transport proposal _____ 12
 - Load charts _____ 13
 - Working Range _____ 13
 - Telescopic Boom _____ 14
 - Working Range _____ 26
 - Swingaway (hydraulic luffing) _____ 27
 - Swingaway with jib extension (hydraulic luffing) _____ 35
 - Working Range _____ 37
 - Swingaway with boom extension (hydraulic luffing) _____ 38
- Specification** _____ **40**
- Load charts** _____ **41**
- Symbols glossary** _____ **42**

Dimensions

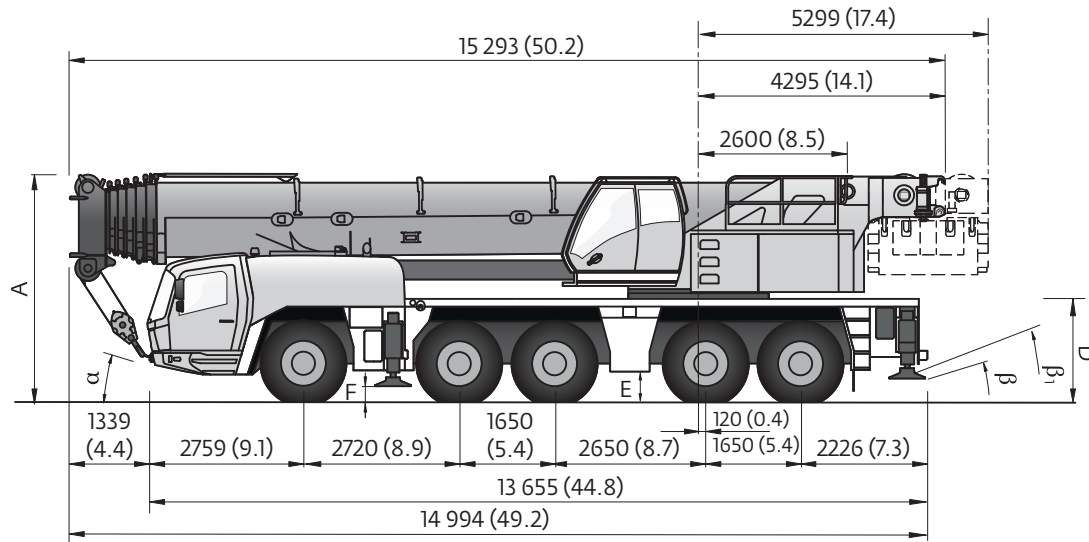

Dimensions shown are in mm (ft).

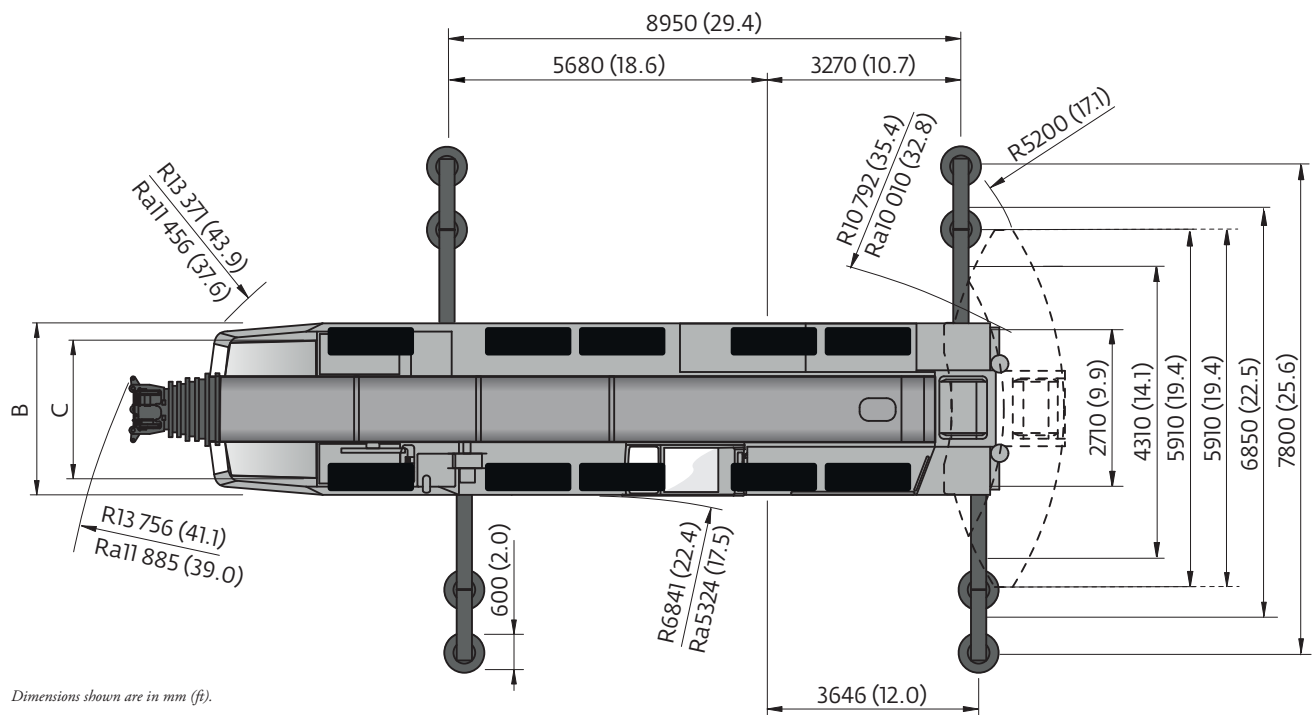

Dimensions shown are in mm (ft).

Ra = Radius all wheels steered

	A	A 130 mm**	B	C	D	E	F	α	β	β_1	
	385/95 R25	3950 (13.0)	3820 (12.5)	3000 (9.8)	2570 (8.4)	1822 (6.0)	486 (1.6)	228 (0.8)	14	8	6
	445/95 R25	4000 (13.1)	3870 (12.7)	3000 (9.8)	2510 (8.2)	1872 (6.1)	536 (1.8)	278 (0.9)	16	10	8
	525/80 R25	4000 (13.1)	3870 (12.7)	3100 (10.2)	2530 (8.3)	1872 (6.1)	536 (1.8)	278 (0.9)	16	10	8

** Lowered

Weights

Boom over front

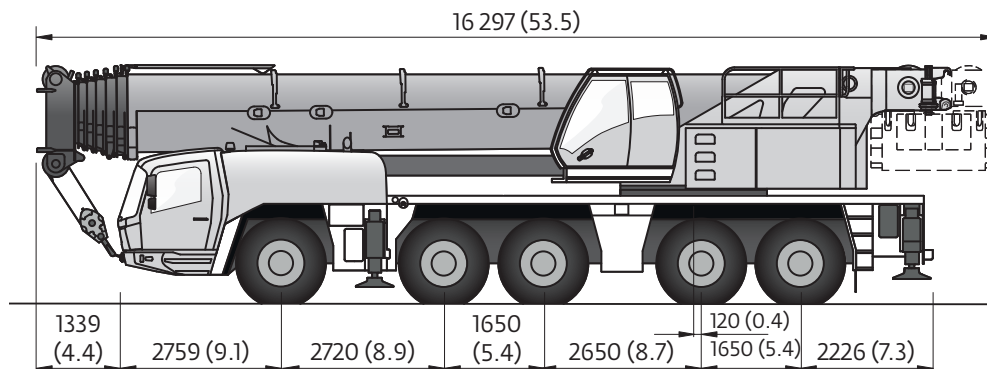

Dimensions shown are in mm (ft).

Basic Weights - kg (lb)	Axles 1 and 2	Axles 3-5	Total
Mercedes power Tier 4 Final, 16.00 R25 tires, 10x6x10 drive/steer, 2nd oil cooler, nylatron outrigger pads, full fuel tank.	23.240 kg (51,220 lb)	35.760 kg (78,840 lb)	58.990 kg (130,050)
Additions			
10X8X10 drive/steer	182 kg (401 lb)	209 kg (460 lb)	209 kg (861 lb)
Spare wheel 14.00 R25 XGC steel rim with stowage	-224 kg (-493 lb)	509 kg (1122 lb)	285 kg (628 lb)
Spare wheel 16.00 R25 XGC steel rim with stowage	-265 kg (-585 lb)	603 kg (1330 lb)	338 kg (745 lb)
Spare wheel 20.5 R25 XGC steel rim with stowage	-315 kg (-694 lb)	716 kg (1578 lb)	401 kg (884 lb)
Brackets for hydraulic swingaway	207 kg (456 lb)	3 kg (7 lb)	210 kg (463 lb)
Hose reel for hydraulic swingaway	270 kg (596 lb)	-85 kg (-188 lb)	185 kg (408 lb)
12,5 m - 21,3 m (39 ft - 69 ft) hydraulic swingaway	2998 kg (6609 lb)	-146 kg (-321 lb)	2852 kg (6288 lb)
Auxiliary hoist	-2098 kg (-4626 lb)	4353 kg (9597 lb)	2255 kg (4971 lb)
7000 kg (15,400 lb) base plate stowed on carrier	4770 kg (10,515 lb)	1943 kg (4285 lb)	6713 kg (14,800 lb)
7000 kg (15,400 lb) base plate fixed to turntable	-5306 kg (-11,700 lb)	-4349 kg (26,500 lb)	6713 kg (14,800 lb)
Substitutions			
14.00R25 tires	-212 kg (-468 lb)	-318 kg (-702 lb)	530 kg (-1170 lb)
20.5R25 tires	252 kg (556 lb)	378 kg (834 lb)	630 kg (1390 lb)
Removals			
Boom assembly w/o lift cylinder	-14.242 kg (-31,399 lb)	-6514 kg (-14,361 lb)	-20.756 kg (-45,760 lb)
Front outriggers	-2063 kg (-4549 lb)	-15 kg (-34 lb)	-2078 kg (-4583 lb)
Rear outriggers	1772 kg (3907 lb)	-4349 kg (-9588 lb)	-2577 kg (-5681 lb)
Front and rear nylatron outrigger floats	-18 kg (-40 lb)	-36 kg (-80 lb)	-54 kg (-120 lb)

Weights

Trailing Boom

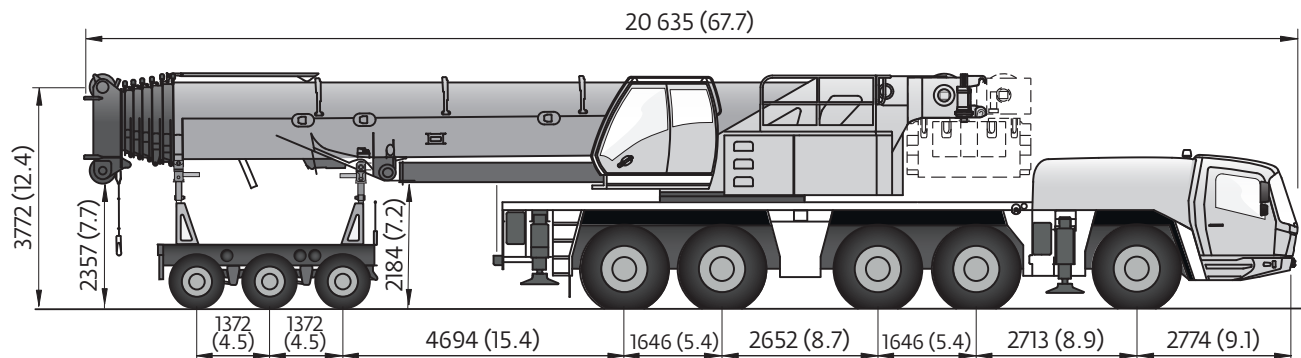

Dimensions shown are in mm (ft).

Basic Weights - kg (lb)	Axles 1 and 2	Axles 3-5	Dolly	Total
GMK 5250L Mercedes power Tier 4 Final with: 20.5R25 tires, 10x8x10 drive/steer, 12,5 m-21,3m (39-69 ft) hydraulic luffing swingaway, 2 line boom nose, 2nd oil cooler, nylatron outrigger pads, auxiliary hoist, full fuel tank, 3 axle boom dolly (4309 kg / 9400 lb)"	18.851 kg (41,560 lb)	30.386 kg (66,990 lb)	20.752 kg (45,750 lb)	69.990 kg (154,300 lb)
Additions				
7000 kg (15,400 lb) base plate stowed on carrier	4770 kg (10,515 lb)	1943 kg (4285 lb)	0 kg (0 lb)	6713 kg (14,800 lb)
7000 kg (15,400 lb) base plate fixed to turntable	4770 kg (10,515 lb)	1943 kg (4285 lb)	0 kg (0 lb)	6713 kg (14,800 lb)
Removals				
Brackets for hydraulic swingaway incl. hose reel	-27 kg (-60 lb)	-41 kg (-90 lb)	-331 kg (-730 lb)	-399 kg (-880 lb)
12,5 m - 21,3 m (39 ft - 69 ft) hydraulic swingaway	-318 kg (-700 lb)	-394 kg (-870 lb)	-2140 kg (-4718 lb)	-2852 kg (-6288 lb)
Auxiliary hoist	-1917 kg (-4227 lb)	-337 kg (-744 lb)	0 kg (0 lb)	-2254 kg (-4971 lb)
2 line boom nose	18 kg (40 lb)	27 kg (60 lb)	-260 kg (-574 lb)	-215 kg (-474 lb)
Front outriggers	-2063 kg (-4549 lb)	-15 kg (-34 lb)	0 kg (0 lb)	-2078 kg (-4583 lb)
Rear outriggers	1772 kg (3907 lb)	-4349 kg (-9588 lb)	0 kg (0 lb)	-2577 kg (-5681 lb)
Front and rear nylatron outrigger floats	-18 kg (-40 lb)	-36 kg (-80 lb)	0 kg (0 lb)	-54 kg (-120 lb)
Substitutions				
10X6X10 drive/steer	-182 kg (-401 lb)	-208 kg (-460 lb)	0 kg (0 lb)	-390 kg (-861 lb)
14.00R25 tires	-464 kg (-1023 lb)	-696 kg (-1535 lb)	0 kg (0 lb)	-1160 kg (-2558 lb)
16.00R25 tires	-252 kg (-555 lb)	-378 kg (-834 lb)	0 kg (0 lb)	-630 kg (-1389 lb)

Data



Lifting Capacity	Sheaves	Weight	Parts of line	Possible load with crane*
200 t (220 USt)	9	2400 kg (5291 lb)	2-18 ▪	180 t (198 USt) ▪
160 t (176 USt)	7	1750 kg (3858 lb)	2-15	150 t (165 USt)
125 t (137 USt)	5	1650 kg (3638 lb)	2 - 11	110 t (121 USt)
80 t (88 USt)	3	950 kg (2095 lb)	2 - 7	70 t (77 USt)
32 t (35 USt)	1	600 kg (1323 lb)	2 - 3	30 t (33 USt)
12 t (13 USt)	H/B	300 kg (662 lb)	1	10 t (11 USt)

* varies depending on national regulations
 ▪ 0° over rear with additional equipment

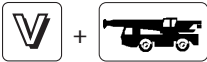

	1	2	3	4	5	6	7	8	9	10	11	12	R	
mph	3.4	4.3	5.6	7.2	9.1	11.7	15.5	19.9	25.5	32.9	41.6	52.8	3.7	50 %
	14.00R25 (385/95R25), 16.00R25 (445/95R25), 20.5R25 (525/80R25)													

* Theoretical gradeability



	Infinitely variable	Rope	Max. single line pull
	0 - 125 m/min (0 - 410 Fpm) Single line	22 mm/300 m (22 mm/984 ft)	93.5 kN (21,020 lb)
	0 - 125 m/min (0 - 410 Fpm) Single line	22 mm/300 m (22 mm/1083 ft)	93.5 kN (21,020 lb)
	0 - 1,45 min ⁻¹		
	-1,5° to + 82° approx. 65 s		
	13,3 to 70,0 m (43.6 to 229.7 ft) approx. 515 s		

Dimensions

Counterweight

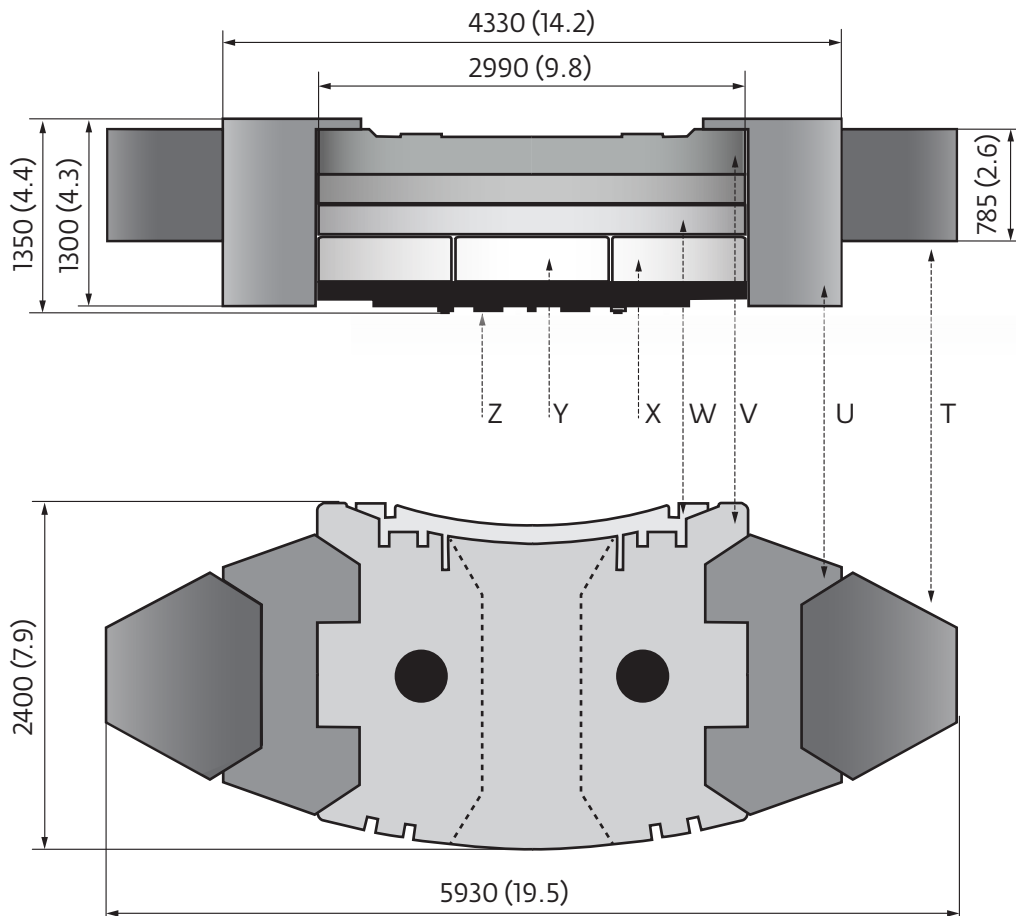

Dimensions shown are in mm (ft).

	Z 7,0 t (7.7 USt)	Y 4,5 t (5.0 USt)	X 4,75 t (5.2 USt)	W 9,5 t (10.5 USt)	V 10,0 t (11.0 USt)	U 10,0 t (11.0 USt)	T 5,0 t (5.5 USt)
7,0 t (7.7 USt)	x						
16,5 t (18.2 USt)	x		2 x				
21,0 t (23.1 USt)	x	x	2 x				
26,0 t (28.7 USt)	x		2 x	x			
30,5 t (33.6 USt)	x	x	2 x	x			
35,5 t (39.1 USt)	x		2 x	2 x			
40,0 t (44.1 USt)	x	x	2 x	2 x			
45,5 t (50.2 USt)	x		2 x	2 x	x		
50,0 t (55.1 USt)	x	x	2 x	2 x	x		
70,0 t (77.2 USt)	x	x	2 x	2 x	x	2 x	
80,0 t (88.2 USt)	x	x	2 x	2 x	x	2 x	2 x

Dimensions

Auxiliary hoist

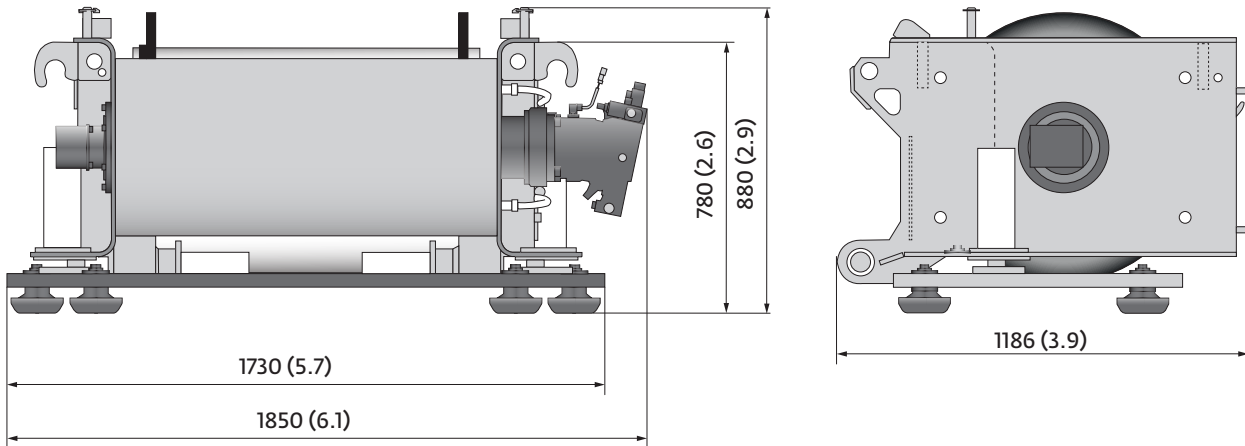

Dimensions shown are in mm (ft).

kg (lb)	2255 (4972)
---------	-------------

Hose reel

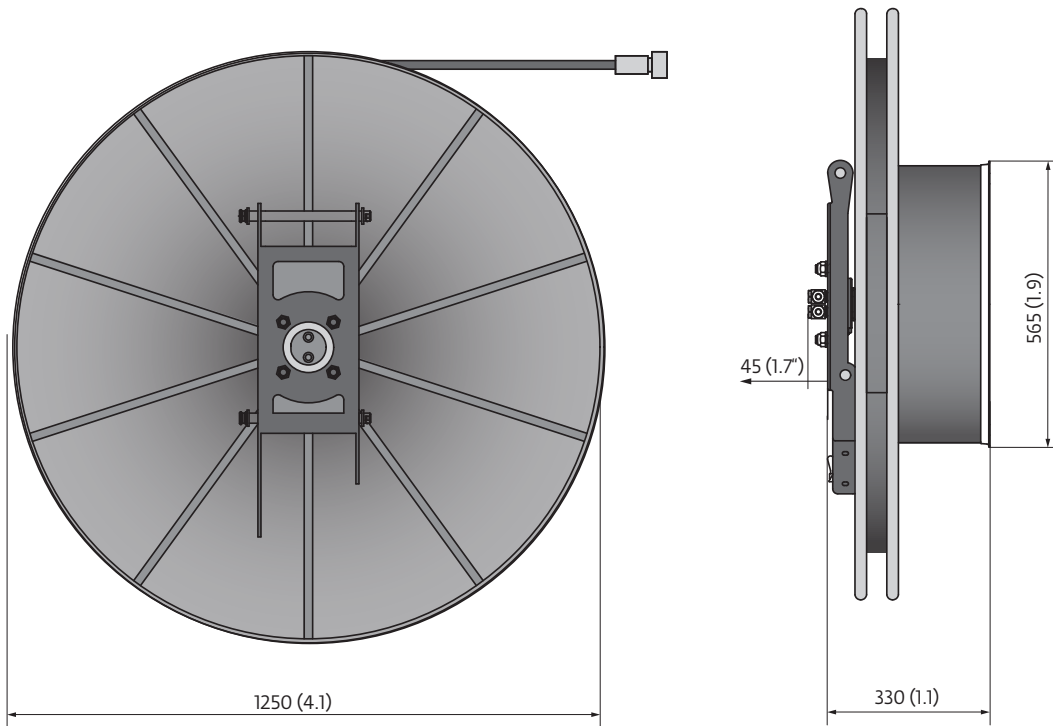

Dimensions shown are in mm (ft).

kg (lbs)	185 (408)
----------	-----------

Dimensions

Jib combinations

	L x W x h	kg / lb
A	4,2 x 1,0 x 1,6 m (18.8' x 3.3' x 5.3')	1760 / 3880
B	8,7 x 7,2 x 1,1 m (28.5' x 23.6' x 3.6')	712 / 1570
C	9,0 x 0,5 x 0,9 m (29.5' x 1.6' x 3.0')	525 / 1158
D	8,2 x 0,7 x 1,1 m (26.9' x 2.3' x 3.6')	650 / 1433
E	8,2 x 0,9 x 1,2 m (26.9' x 3.0' x 3.9')	715 / 1576

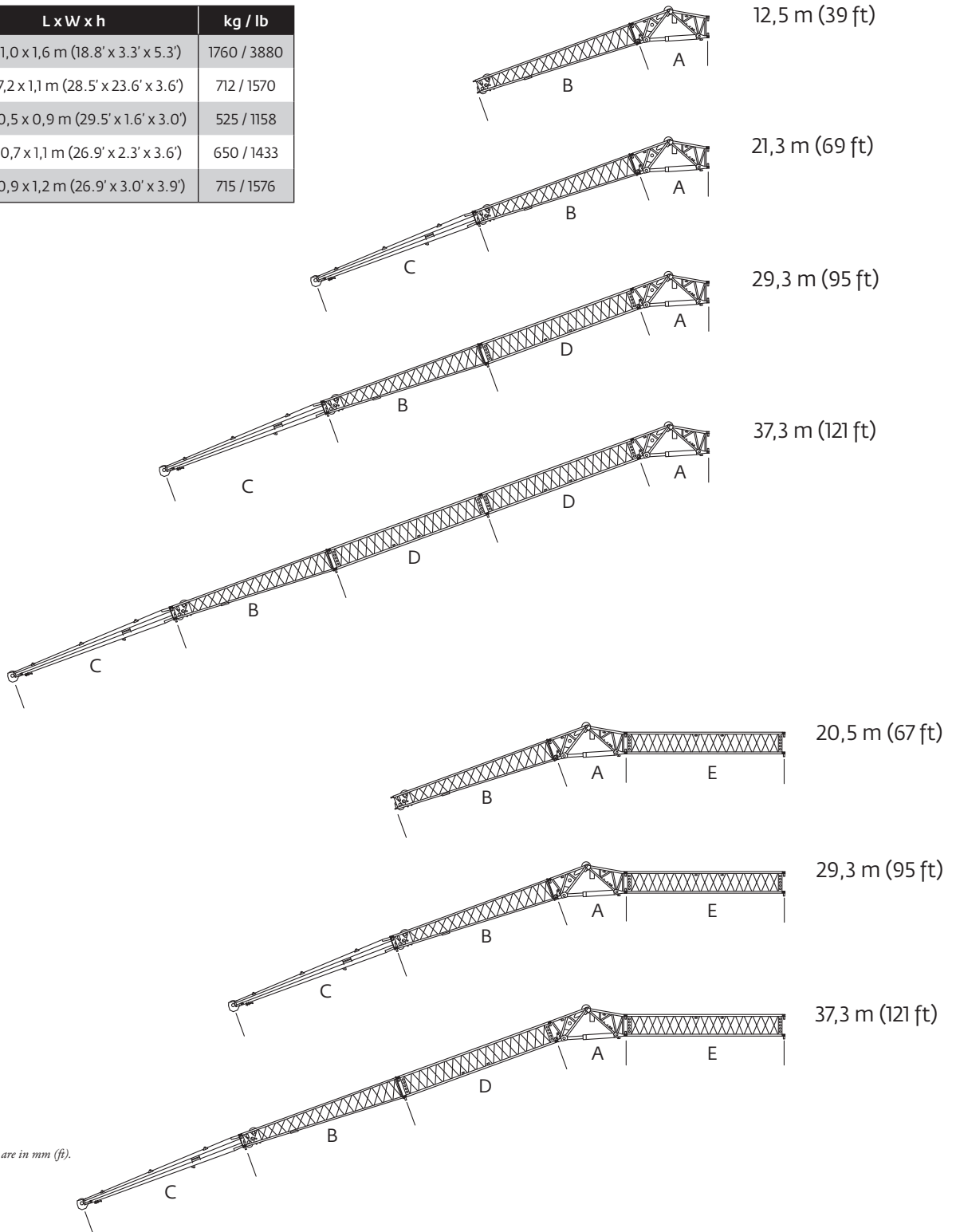

Dimensions

Transport proposal

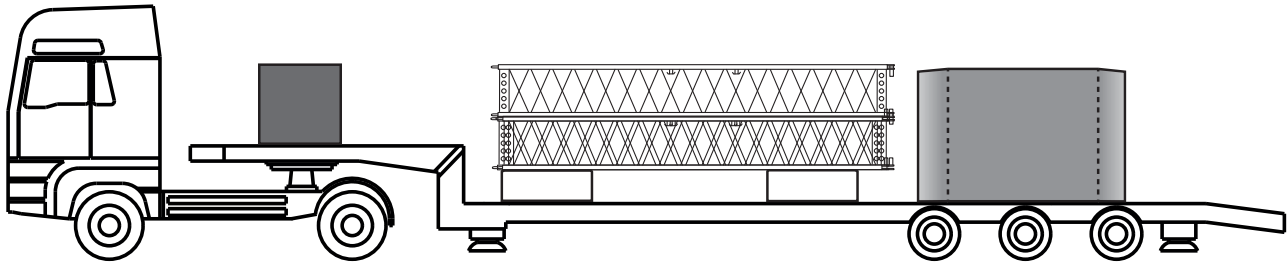

2 x D	E	2 x X	U	T
1300 kg (2866 lb)	715 kg (1576 lb)	4,75 t (5.24 USt)	10 t (11 USt)	5 t (5.5 USt)

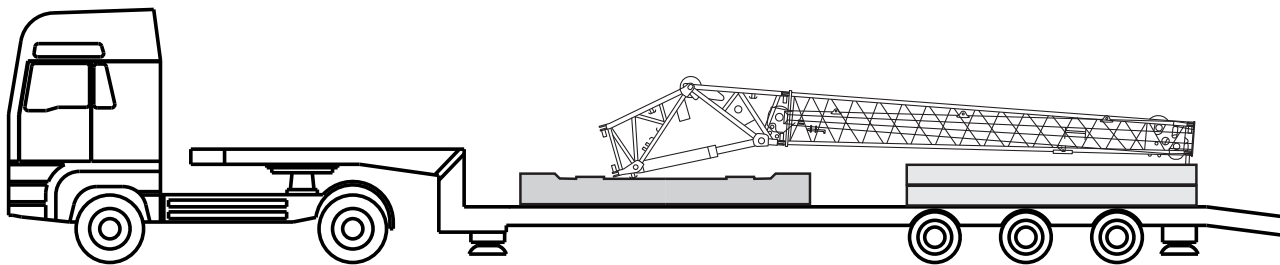

A	B	C	V	2 x W
1760 kg (3880 lb)	712 kg (1570 lb)	525 kg (1158 lb)	10 t (11 USt)	9,5 t (10.5 USt)



Z	Y	H	U	T
7 t (7.7 USt)	4,5 t (5.0 USt)	2550 kg (4960 lb)	10 t (11 USt)	5 t (5.5 USt)

Working range



13,3 m - 70,0 m (44 ft - 229.7 ft)



7,8 m (25.6 ft)



360°



80 t (176,300 lb)

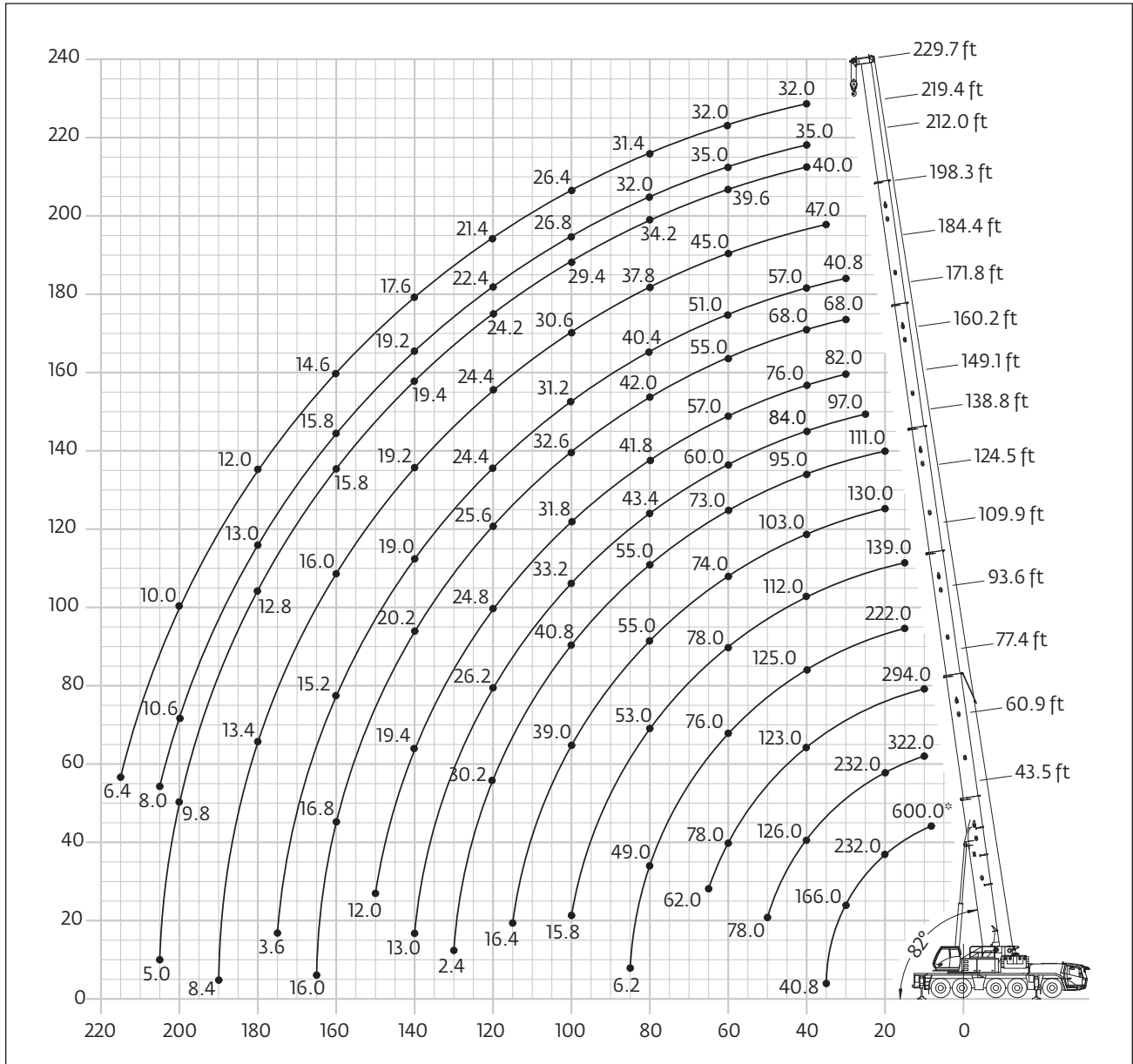

	Hook block t (USt)	
	200 D (220 D)	H
	160 D (176 D)	3800 mm (12.5 ft)
	125 D (138 D)	3650 mm (12.0 ft)
	80 E/D (88 E/D)	3600 mm (11.8 ft)
	32 E (35 E)	3600 mm (11.8 ft)
	12 H/B (13 H/B)	3400 mm (11.2 ft)
		2800 mm (9.2 ft)

THIS CHART IS ONLY A GUIDE AND SHOULD NOT BE USED TO OPERATE THE CRANE.

The individual crane's load chart, operating instructions and other instructional plates must be read and understood prior to operating the crane

Load charts

Telescopic boom



13,3 m - 70,0 m (44 ft - 229.7 ft)



7,8 m (25.6 ft)



360°



80 t (176,300 lb)



Pounds x 1000

Feet	43.5	60.9	77.4	93.6	109.9	124.5	138.8	149.1	160.2	171.8	184.4	198.3	212.0	219.4	229.7	Feet
8.0	600.0*															8.0
9.0	382.0															9.0
10.0	360.0	322.0	294.0													10.0
15.0	284.0	284.0	254.0	220.0	139.0											15.0
20.0	232.0	232.0	228.0	199.0	165.0	130.0	111.0									20.0
25.0	195.0	196.0	192.0	176.0	154.0	129.0	111.0	97.0								25.0
30.0	166.0	167.0	164.0	156.0	138.0	122.0	108.0	96.0	82.0	68.0	40.8					30.0
35.0	40.8	144.0	141.0	140.0	124.0	113.0	102.0	91.0	80.0	68.0	57.0	47.0				35.0
40.0		126.0	123.0	125.0	112.0	103.0	95.0	84.0	76.0	68.0	57.0	47.0	40.0	35.0	32.0	40.0
45.0		109.0	108.0	110.0	102.0	95.0	89.0	77.0	72.0	66.0	57.0	47.0	40.0	35.0	32.0	45.0
50.0		78.0	98.0	96.0	93.0	87.0	83.0	71.0	67.0	62.0	56.0	47.0	40.0	35.0	32.0	50.0
55.0			87.0	86.0	85.0	80.0	78.0	65.0	62.0	59.0	54.0	47.0	40.0	35.0	32.0	55.0
60.0			78.0	76.0	78.0	74.0	73.0	60.0	57.0	55.0	51.0	45.0	39.6	35.0	32.0	60.0
65.0			62.0	69.0	70.0	68.0	68.0	55.0	53.0	52.0	48.0	43.4	38.4	34.8	32.0	65.0
70.0				63.0	64.0	64.0	63.0	51.0	49.0	48.0	45.0	41.6	37.0	34.2	31.8	70.0
75.0				59.0	58.0	60.0	59.0	47.0	45.0	45.0	43.0	39.8	35.6	33.2	31.8	75.0
80.0				49.0	53.0	55.0	55.0	43.4	41.8	42.0	40.4	37.8	34.2	32.0	31.4	80.0
85.0				6.2	49.0	51.0	52.0	40.4	38.8	39.4	37.6	36.0	33.0	30.6	30.2	85.0
90.0					45.0	46.0	48.0	38.0	36.4	37.0	35.4	34.2	31.8	29.4	28.8	90.0
95.0					40.0	42.4	44.0	35.6	34.0	34.8	33.2	32.4	30.6	28.0	27.6	95.0
100.0					15.8	39.0	40.8	33.2	31.8	32.6	31.2	30.6	29.4	26.8	26.4	100.0
105.0						36.0	37.8	31.4	30.0	30.6	29.4	29.0	28.2	25.8	25.2	105.0
110.0						31.8	35.0	29.4	28.2	28.8	27.4	27.4	26.8	24.6	24.0	110.0
115.0						16.4	32.4	27.8	26.4	27.2	25.8	25.8	25.6	23.4	22.8	115.0
120.0							30.2	26.2	24.8	25.6	24.4	24.4	24.2	22.4	21.4	120.0
125.0							25.6	24.6	23.2	24.0	22.8	22.8	23.0	21.6	20.4	125.0
130.0							2.4	23.0	21.8	22.4	21.2	21.4	21.6	20.8	19.4	130.0
135.0								21.0	20.4	21.2	20.0	20.2	20.4	20.0	18.6	135.0
140.0								13.0	19.4	20.2	19.0	19.2	19.4	19.2	17.6	140.0
145.0									18.2	19.0	17.8	18.0	18.4	18.4	16.8	145.0
150.0									12.0	18.2	17.0	17.4	17.6	17.6	16.0	150.0
155.0										17.4	16.2	16.6	16.8	16.8	15.4	155.0
160.0										16.8	15.2	16.0	15.8	15.8	14.6	160.0
165.0										16.0	14.4	15.2	15.0	15.0	13.8	165.0
170.0											12.8	14.6	14.2	14.4	13.2	170.0
175.0												14.0	13.6	13.6	12.6	175.0
180.0													13.4	12.8	13.0	180.0
185.0													13.0	12.2	12.4	185.0
190.0														11.6	11.8	190.0
195.0														8.4	11.0	195.0
200.0															11.2	200.0
205.0															10.6	205.0
210.0															8.0	210.0
215.0															9.0	215.0
															6.4	

* Over rear with special equipment

THIS CHART IS ONLY A GUIDE AND SHOULD NOT BE USED TO OPERATE THE CRANE.

The individual crane's load chart, operating instructions and other instructional plates must be read and understood prior to operating the crane

Load charts

Telescopic boom



13,3 m - 70,0 m (44 ft - 229.7 ft)



7,8 m (25.6 ft)



360°



70 t (154,300 lb)



Pounds x 1000

Feet	43.5	60.9	77.4	93.6	109.9	124.5	138.8	149.1	160.2	171.8	184.4	198.3	212.0	219.4	229.7	Feet
9.0	378.0															9.0
10.0	358.0	322.0	294.0													10.0
15.0	282.0	280.0	254.0	220.0	139.0											15.0
20.0	230.0	230.0	226.0	199.0	165.0											20.0
25.0	192.0	193.0	190.0	176.0	154.0	129.0	111.0	97.0								25.0
30.0	163.0	164.0	161.0	156.0	138.0	122.0	108.0	96.0	82.0	68.0	40.8					30.0
35.0	40.8	141.0	138.0	140.0	124.0	113.0	102.0	91.0	80.0	68.0	57.0	47.0				35.0
40.0		122.0	119.0	121.0	112.0	103.0	95.0	84.0	76.0	68.0	57.0	47.0	40.0	35.0	32.0	40.0
45.0		106.0	106.0	104.0	102.0	95.0	89.0	77.0	72.0	66.0	57.0	47.0	40.0	35.0	32.0	45.0
50.0		78.0	93.0	91.0	93.0	87.0	83.0	71.0	67.0	62.0	56.0	47.0	40.0	35.0	32.0	50.0
55.0			82.0	81.0	83.0	80.0	78.0	65.0	62.0	59.0	54.0	47.0	40.0	35.0	32.0	55.0
60.0			74.0	73.0	74.0	74.0	73.0	60.0	57.0	55.0	51.0	45.0	39.6	35.0	32.0	60.0
65.0			62.0	67.0	66.0	67.0	68.0	55.0	53.0	52.0	48.0	43.4	38.4	34.8	32.0	65.0
70.0				61.0	59.0	61.0	61.0	51.0	49.0	48.0	45.0	41.6	37.0	34.2	31.8	70.0
75.0				55.0	53.0	55.0	56.0	47.0	45.0	45.0	43.0	39.8	35.6	33.2	31.8	75.0
80.0				49.0	50.0	49.0	51.0	43.4	41.8	42.0	40.4	37.8	34.2	32.0	31.4	80.0
85.0				6.2	47.0	45.0	47.0	40.4	38.8	39.4	37.6	36.0	33.0	30.6	30.2	85.0
90.0					42.6	41.8	42.6	38.0	36.4	37.0	35.4	34.2	31.8	29.4	28.8	90.0
95.0					38.6	39.6	39.0	35.6	34.0	34.8	33.2	32.4	30.6	28.0	27.6	95.0
100.0					23.2	37.4	35.8	33.2	31.8	32.6	31.2	30.6	29.4	26.8	26.4	100.0
105.0					6.0	34.8	33.0	31.4	30.0	30.6	29.4	29.0	28.2	25.8	25.2	105.0
110.0						29.2	30.2	29.0	28.2	28.8	27.4	27.4	26.8	24.6	24.0	110.0
115.0						16.4	27.8	26.6	26.4	27.2	25.8	25.8	25.6	23.4	22.8	115.0
120.0							25.6	24.4	24.2	25.6	24.4	24.4	24.2	22.4	21.4	120.0
125.0							23.6	22.4	22.2	23.8	22.8	22.8	23.0	21.6	20.4	125.0
130.0							2.4	20.6	20.4	22.0	21.2	21.4	21.6	20.8	19.4	130.0
135.0								19.0	18.6	20.2	19.4	20.2	20.4	20.0	18.6	135.0
140.0								13.0	17.2	19.2	18.0	19.0	19.4	19.2	17.6	140.0
145.0									15.6	18.4	16.4	18.0	18.4	18.4	16.8	145.0
150.0									12.0	18.0	15.4	17.4	17.4	17.6	16.0	150.0
155.0									11.6	17.4	14.8	16.6	16.0	16.4	15.4	155.0
160.0										16.4	14.2	15.8	14.8	15.2	14.6	160.0
165.0										15.2	13.4	14.6	13.8	14.2	13.8	165.0
170.0											12.8	13.6	12.8	13.0	12.6	170.0
175.0												3.6	12.8	12.2	11.8	175.0
180.0													11.8	11.8	10.8	180.0
185.0													11.0	11.2	10.4	185.0
190.0													8.4	10.4	9.6	190.0
195.0														9.6	8.8	195.0
200.0														8.8	8.2	200.0
205.0														5.0	7.4	205.0
210.0															6.4	210.0

THIS CHART IS ONLY A GUIDE AND SHOULD NOT BE USED TO OPERATE THE CRANE.

The individual crane's load chart, operating instructions and other instructional plates must be read and understood prior to operating the crane

Load charts

Telescopic boom



13,3 m - 70,0 m (44 ft - 229.7 ft)



7,8 m (25.6 ft)



360°



50 t (110,200 lb)



Pounds x 1000

Feet	43.5	60.9	77.4	93.6	109.9	124.5	138.8	149.1	160.2	171.8	184.4	198.3	212.0	219.4	229.7	Feet
9.0	370.0															9.0
10.0	350.0	322.0	294.0													10.0
15.0	276.0	274.0	254.0	220.0	139.0											15.0
20.0	222.0	224.0	220.0	199.0	165.0	130.0	111.0									20.0
25.0	185.0	186.0	183.0	176.0	154.0	129.0	111.0	97.0								25.0
30.0	153.0	154.0	151.0	147.0	138.0	122.0	108.0	96.0	82.0	68.0	40.8					30.0
35.0	40.8	129.0	128.0	120.0	117.0	113.0	102.0	91.0	80.0	68.0	57.0	47.0				35.0
40.0		111.0	107.0	104.0	98.0	97.0	95.0	84.0	76.0	68.0	57.0	47.0	40.0	35.0	32.0	40.0
45.0		93.0	91.0	90.0	86.0	83.0	83.0	77.0	72.0	66.0	57.0	47.0	40.0	35.0	32.0	45.0
50.0		71.0	80.0	78.0	77.0	74.0	72.0	70.0	67.0	62.0	56.0	47.0	40.0	35.0	32.0	50.0
55.0			68.0	68.0	68.0	68.0	64.0	61.0	60.0	59.0	54.0	47.0	40.0	35.0	32.0	55.0
60.0			59.0	62.0	60.0	61.0	57.0	54.0	53.0	52.0	51.0	45.0	39.6	35.0	32.0	60.0
65.0			52.0	55.0	53.0	55.0	51.0	48.0	47.0	48.0	46.0	43.4	38.4	34.8	32.0	65.0
70.0				48.0	47.0	49.0	45.0	43.2	42.2	43.0	41.4	41.6	37.0	34.2	31.8	70.0
75.0				43.2	42.0	44.0	41.0	38.8	37.8	38.8	37.4	37.6	35.6	33.2	31.8	75.0
80.0				37.2	37.4	39.8	37.0	35.0	34.2	35.2	33.8	34.0	34.2	32.0	31.4	80.0
85.0				6.2	33.6	35.8	33.6	31.6	30.8	31.8	31.2	32.6	31.8	30.6	30.2	85.0
90.0					30.2	32.4	32.2	28.8	28.0	29.6	29.6	30.4	29.0	29.0	28.2	90.0
95.0					27.2	29.4	30.8	26.0	25.4	28.4	28.0	28.0	26.8	26.6	25.8	95.0
100.0					15.8	26.8	28.4	23.2	23.0	27.0	26.4	25.6	25.4	24.4	23.8	100.0
105.0						24.4	26.0	20.8	21.2	24.8	24.8	23.6	23.4	22.4	21.8	105.0
110.0						22.2	23.8	19.4	20.0	23.0	23.2	21.8	21.6	20.6	20.0	110.0
115.0						16.2	21.8	18.6	19.0	21.2	21.8	20.2	19.8	19.0	18.4	115.0
120.0							20.2	17.8	18.0	19.4	20.2	18.8	18.4	17.6	16.8	120.0
125.0							18.6	17.0	17.2	17.8	18.6	17.8	17.0	16.2	15.4	125.0
130.0							2.4	16.2	16.4	16.2	17.0	16.8	15.6	14.8	14.2	130.0
135.0								15.6	15.6	15.0	15.8	16.0	14.4	13.6	13.0	135.0
140.0								13.0	15.0	13.6	15.0	14.6	13.4	12.6	12.0	140.0
145.0									14.2	12.4	14.4	13.6	12.2	11.4	10.8	145.0
150.0									12.0	11.4	13.4	12.4	11.2	10.4	10.0	150.0
155.0									11.6	10.4	12.4	11.4	10.0	9.4	9.0	155.0
160.0										9.4	11.4	10.4	9.2	8.4	8.0	160.0
165.0										8.6	10.6	9.6	8.2	7.6	7.2	165.0
170.0											9.8	8.8	7.4	6.6	6.2	170.0
175.0											3.6	8.0	6.6	6.0	5.6	175.0
180.0												7.2	6.0	5.2	4.8	180.0
185.0												6.6	5.2	4.6	4.2	185.0
190.0												4.4	4.6	3.8	3.4	190.0
195.0													4.0	3.2	2.8	195.0
200.0													3.4	2.8	2.2	200.0
205.0													3.0	2.2		205.0

THIS CHART IS ONLY A GUIDE AND SHOULD NOT BE USED TO OPERATE THE CRANE.

The individual crane's load chart, operating instructions and other instructional plates must be read and understood prior to operating the crane

Load charts

Telescopic boom



13,3 m - 70,0 m (44 ft - 229.7 ft)



7,8 m (25.6 ft)



360°



45,5 t (100,300 lb)



Pounds x 1000

Feet	43.5	60.9	77.4	93.6	109.9	124.5	138.8	149.1	160.2	171.8	184.4	198.3	212.0	219.4	229.7	Feet
9.0	368.0															9.0
10.0	348.0	322.0	294.0													10.0
15.0	274.0	274.0	254.0	220.0	139.0											15.0
20.0	222.0	222.0	219.0	199.0	165.0	130.0	111.0									20.0
25.0	183.0	184.0	181.0	176.0	154.0	129.0	111.0	97.0								25.0
30.0	149.0	150.0	149.0	138.0	134.0	122.0	108.0	96.0	82.0	68.0	40.8					30.0
35.0	40.8	125.0	121.0	117.0	109.0	108.0	102.0	91.0	80.0	68.0	57.0	47.0				35.0
40.0		105.0	100.0	98.0	95.0	91.0	90.0	84.0	76.0	68.0	57.0	47.0	40.0	35.0	32.0	40.0
45.0		87.0	88.0	84.0	83.0	80.0	78.0	74.0	72.0	66.0	57.0	47.0	40.0	35.0	32.0	45.0
50.0		65.0	74.0	73.0	72.0	73.0	68.0	65.0	63.0	62.0	56.0	47.0	40.0	35.0	32.0	50.0
55.0			63.0	66.0	63.0	64.0	59.0	57.0	55.0	54.0	54.0	47.0	40.0	35.0	32.0	55.0
60.0			57.0	58.0	56.0	57.0	52.0	50.0	49.0	49.0	48.0	45.0	39.6	35.0	32.0	60.0
65.0			50.0	50.0	49.0	51.0	47.0	44.0	43.2	44.0	42.4	42.4	38.4	34.8	32.0	65.0
70.0				45.0	43.4	45.0	41.6	39.4	38.4	39.4	37.8	38.0	37.0	34.2	31.8	70.0
75.0				40.2	38.4	40.8	37.4	35.4	34.4	35.4	34.2	35.4	35.0	33.2	31.8	75.0
80.0				35.4	34.2	36.6	35.2	31.8	30.8	32.6	32.6	33.2	31.8	31.8	30.8	80.0
85.0				6.2	30.4	32.8	33.6	28.6	27.8	31.0	31.2	30.2	29.6	28.8	28.0	85.0
90.0					27.2	29.6	31.4	25.8	25.4	29.0	29.6	27.6	27.2	26.4	25.6	90.0
95.0					24.4	26.8	28.4	23.2	23.8	26.6	27.2	25.4	25.0	24.0	23.2	95.0
100.0					15.8	24.2	25.8	21.4	22.4	24.4	25.0	24.0	22.8	22.0	21.2	100.0
105.0						22.0	23.6	20.4	21.2	22.4	23.0	22.6	21.0	20.2	19.4	105.0
110.0						20.0	21.6	19.4	20.0	20.6	21.4	21.0	19.2	18.4	17.8	110.0
115.0						14.0	19.8	18.6	19.0	19.0	19.6	19.6	17.8	16.8	16.2	115.0
120.0							18.0	17.8	18.0	17.4	18.2	18.0	16.2	15.4	14.8	120.0
125.0							16.6	17.0	17.2	15.8	17.2	16.8	15.0	14.2	13.4	125.0
130.0							2.4	16.2	16.4	14.4	16.4	15.4	13.8	13.0	12.2	130.0
135.0								15.6	15.6	13.0	15.2	14.2	12.6	11.8	11.2	135.0
140.0								13.0	14.4	11.8	14.0	13.0	11.6	10.8	10.2	140.0
145.0									13.4	10.8	12.8	11.8	10.4	9.8	9.2	145.0
150.0									12.0	9.8	11.8	10.8	9.4	8.8	8.2	150.0
155.0									11.6	8.8	10.8	9.8	8.6	7.8	7.4	155.0
160.0										8.0	10.0	9.0	7.6	6.8	6.4	160.0
165.0										7.2	9.0	8.0	6.8	6.0	5.6	165.0
170.0											8.4	7.4	6.0	5.2	4.8	170.0
175.0											3.6	6.6	5.2	4.6	4.2	175.0
180.0												5.8	4.6	3.8	3.4	180.0
185.0												5.2	4.0	3.2	2.8	185.0
190.0												3.2	3.4	2.6	2.2	190.0
195.0													2.8	2.0		195.0
200.0													2.2			200.0

THIS CHART IS ONLY A GUIDE AND SHOULD NOT BE USED TO OPERATE THE CRANE.

The individual crane's load chart, operating instructions and other instructional plates must be read and understood prior to operating the crane

Load charts

Telescopic boom



13,3 m - 70,0 m (44 ft - 229.7 ft)



7,8 m (25.6 ft)



360°



40 t (88,100 lb)



Pounds x 1000

Feet	43.5	60.9	77.4	93.6	109.9	124.5	138.8	149.1	160.2	171.8	184.4	198.3	212.0	219.4	229.7	Feet
9.0	366.0															9.0
10.0	346.0	322.0	294.0													10.0
15.0	272.0	272.0	254.0	220.0	139.0											15.0
20.0	219.0	220.0	217.0	199.0	165.0	130.0	111.0									20.0
25.0	178.0	180.0	174.0	164.0	154.0	129.0	111.0	97.0								25.0
30.0	144.0	146.0	138.0	131.0	123.0	120.0	108.0	96.0	82.0	68.0	40.8					30.0
35.0	40.8	120.0	111.0	108.0	106.0	99.0	98.0	91.0	80.0	68.0	57.0	47.0				35.0
40.0		96.0	96.0	90.0	89.0	87.0	83.0	79.0	76.0	68.0	57.0	47.0	40.0	35.0	32.0	40.0
45.0		79.0	80.0	80.0	76.0	76.0	71.0	68.0	66.0	64.0	57.0	47.0	40.0	35.0	32.0	45.0
50.0		64.0	67.0	70.0	65.0	66.0	61.0	58.0	57.0	57.0	55.0	47.0	40.0	35.0	32.0	50.0
55.0			60.0	60.0	57.0	58.0	53.0	51.0	49.0	50.0	48.0	47.0	40.0	35.0	32.0	55.0
60.0			52.0	52.0	50.0	51.0	47.0	45.0	43.4	44.0	42.4	42.4	39.6	35.0	32.0	60.0
65.0			45.0	46.0	44.0	46.0	41.6	39.4	38.4	39.2	37.8	38.4	38.4	34.8	32.0	65.0
70.0				42.8	38.8	40.8	39.2	35.0	34.0	36.0	36.0	36.0	34.4	34.2	31.8	70.0
75.0				38.2	34.0	36.6	37.2	31.2	30.4	34.2	34.2	32.6	32.0	31.0	30.0	75.0
80.0				31.4	30.2	32.6	34.0	27.8	28.8	31.0	31.6	29.8	29.0	28.0	27.2	80.0
85.0				6.2	26.8	29.2	31.0	25.6	27.2	28.0	28.8	28.2	26.4	25.4	24.6	85.0
90.0					25.0	26.2	27.8	24.2	25.4	25.6	26.2	26.0	24.0	23.0	22.2	90.0
95.0					21.2	23.4	25.2	22.8	23.8	23.4	24.0	23.8	21.8	21.0	20.2	95.0
100.0					14.8	21.2	22.8	21.4	22.4	21.4	22.2	21.8	19.8	19.0	18.2	100.0
105.0						19.0	20.6	20.4	21.2	19.4	21.0	20.0	18.2	17.2	16.6	105.0
110.0						17.2	18.8	19.4	20.0	17.8	19.8	18.4	16.6	15.6	15.0	110.0
115.0						11.4	17.0	18.6	19.0	16.4	18.4	16.8	15.0	14.2	13.6	115.0
120.0							15.6	17.8	17.4	14.8	17.0	15.6	13.8	13.0	12.2	120.0
125.0							14.2	16.6	16.0	13.4	15.4	14.2	12.6	11.8	11.0	125.0
130.0								15.2	14.6	12.0	14.2	13.2	11.4	10.6	10.0	130.0
135.0								14.0	13.6	10.8	13.0	12.0	10.4	9.6	9.0	135.0
140.0								13.0	12.4	9.8	11.8	10.8	9.4	8.6	8.0	140.0
145.0									11.4	8.8	10.8	9.8	8.4	7.6	7.0	145.0
150.0									10.6	7.8	9.8	8.8	7.4	6.8	6.2	150.0
155.0									9.6	7.0	8.8	7.8	6.6	5.8	5.4	155.0
160.0										6.2	8.0	7.0	5.8	5.0	4.6	160.0
165.0										5.4	7.2	6.2	5.0	4.2	3.8	165.0
170.0											6.6	5.6	4.2	3.6	3.2	170.0
175.0											3.6	4.8	3.6	2.8	2.4	175.0
180.0												4.2	3.0	2.2		180.0
185.0													3.6	2.4		185.0

THIS CHART IS ONLY A GUIDE AND SHOULD NOT BE USED TO OPERATE THE CRANE.

The individual crane's load chart, operating instructions and other instructional plates must be read and understood prior to operating the crane

Load charts

Telescopic boom



13,3 m - 70,0 m (44 ft - 229.7 ft)



7,8 m (25.6 ft)



360°



35,5 t (78,200 lb)



Pounds x 1000

Feet	43.5	60.9	77.4	93.6	109.9	124.5	138.8	149.1	160.2	171.8	184.4	198.3	212.0	219.4	229.7	Feet
9.0	366.0															9.0
10.0	346.0	322.0	294.0													10.0
15.0	270.0	270.0	254.0	220.0	139.0											15.0
20.0	217.0	218.0	215.0	199.0	165.0	130.0	111.0									20.0
25.0	175.0	176.0	168.0	153.0	146.0	129.0	111.0	97.0								25.0
30.0	139.0	141.0	129.0	124.0	118.0	112.0	108.0	96.0	82.0	68.0	40.8					30.0
35.0	40.8	111.0	108.0	101.0	99.0	95.0	91.0	87.0	80.0	68.0	57.0	47.0				35.0
40.0		88.0	89.0	88.0	82.0	82.0	76.0	72.0	70.0	68.0	57.0	47.0	40.0	35.0		40.0
45.0		74.0	74.0	74.0	70.0	70.0	65.0	62.0	60.0	60.0	57.0	47.0	40.0	35.0	32.0	45.0
50.0		60.0	64.0	64.0	60.0	61.0	56.0	53.0	51.0	52.0	50.0	47.0	40.0	35.0	32.0	50.0
55.0			55.0	55.0	52.0	53.0	48.0	46.0	45.0	45.0	43.6	43.6	40.0	35.0	32.0	55.0
60.0			47.0	49.0	45.0	47.0	44.0	40.2	39.0	40.0	39.6	40.2	39.0	35.0	32.0	60.0
65.0			41.0	44.0	40.0	41.2	41.4	35.4	34.4	37.8	37.8	36.2	35.0	34.6	32.0	65.0
70.0					34.8	36.8	37.8	31.2	32.2	34.2	34.8	33.6	32.0	31.0	32.0	70.0
75.0					30.6	33.0	34.0	29.0	30.4	30.8	31.4	31.0	28.8	27.8	30.0	75.0
80.0					27.6	29.4	30.8	27.2	28.8	27.8	28.6	28.2	26.0	25.0	26.8	80.0
85.0					26.2	26.0	27.8	25.6	27.2	25.0	26.8	25.6	23.4	22.6	24.2	85.0
90.0					25.0	23.2	25.0	24.2	25.4	22.8	24.8	23.2	21.2	20.4	21.6	90.0
95.0					18.6	20.8	22.4	22.8	23.8	20.6	22.6	21.2	19.2	18.4	19.6	95.0
100.0					12.2	18.6	20.2	21.4	22.2	18.8	20.8	19.2	17.4	16.6	17.6	100.0
105.0						17.6	18.2	20.4	20.2	17.0	19.0	17.6	15.8	15.0	15.8	105.0
110.0						15.2	17.2	19.0	18.4	15.4	17.6	16.0	14.2	13.4	14.2	110.0
115.0						9.2	16.4	17.4	17.0	14.0	16.0	14.6	13.0	12.0	12.8	115.0
120.0							14.0	16.0	15.4	12.6	14.8	13.4	11.6	10.8	11.4	120.0
125.0							13.4	14.8	14.2	11.4	13.4	12.2	10.6	9.6	10.2	125.0
130.0							2.4	13.6	12.8	10.2	12.2	11.2	9.4	8.6	9.0	130.0
135.0								12.6	11.8	9.0	11.0	10.0	8.4	7.6	8.0	135.0
140.0								11.6	10.8	8.0	10.0	9.0	7.6	6.8	7.0	140.0
145.0									9.8	7.0	9.0	8.0	6.8	6.0	6.2	145.0
150.0									8.8	6.2	8.2	7.2	5.8	5.0	5.4	150.0
155.0									8.0	5.4	7.2	6.4	5.0	4.2	4.6	155.0
160.0										4.6	6.6	5.6	4.2	3.4	3.8	160.0
165.0										3.8	5.8	4.8	3.4	2.8	3.0	165.0
170.0											5.2	4.2	2.8	2.0	2.4	170.0
175.0											3.4	3.4	2.2			175.0
180.0												3.0				180.0
185.0												2.4				185.0

THIS CHART IS ONLY A GUIDE AND SHOULD NOT BE USED TO OPERATE THE CRANE.

The individual crane's load chart, operating instructions and other instructional plates must be read and understood prior to operating the crane

Load charts

Telescopic boom



13,3 m - 70,0 m (44 ft - 229.7 ft)



7,8 m (25.6 ft)



360°



30 t (67,200 lb)



Pounds x 1000

Feet	43.5	60.9	77.4	93.6	109.9	124.5	138.8	149.1	160.2	171.8	184.4	198.3	212.0	219.4	229.7	Feet
9.0	364.0															9.0
10.0	344.0	322.0	294.0													10.0
15.0	268.0	268.0	254.0	220.0	139.0											15.0
20.0	214.0	215.0	206.0	191.0	165.0	130.0	111.0									20.0
25.0	170.0	168.0	154.0	147.0	134.0	129.0	111.0	97.0								25.0
30.0	126.0	130.0	123.0	114.0	111.0	104.0	101.0	96.0	82.0	68.0	40.8					30.0
35.0	40.8	101.0	98.0	97.0	90.0	89.0	82.0	78.0	76.0	68.0	57.0	47.0				35.0
40.0		81.0	81.0	80.0	74.0	74.0	68.0	65.0	63.0	63.0	57.0	47.0	40.0	35.0	32.0	40.0
45.0		66.0	69.0	67.0	63.0	63.0	58.0	55.0	53.0	54.0	52.0	47.0	40.0	35.0	32.0	45.0
50.0		54.0	58.0	58.0	54.0	54.0	50.0	47.0	46.0	46.0	44.0	44.0	40.0	35.0	32.0	50.0
55.0			49.0	53.0	46.0	47.0	47.0	40.8	39.4	42.2	41.8	41.0	39.2	35.0	32.0	55.0
60.0			42.2	46.0	40.2	41.6	42.2	35.4	36.0	38.2	38.8	37.2	35.2	34.4	32.0	60.0
65.0			36.4	39.8	35.2	36.6	37.6	32.4	33.8	33.8	34.4	34.0	31.6	30.6	29.4	65.0
70.0				35.0	30.8	32.6	33.4	30.6	32.2	30.2	32.2	30.4	28.2	27.2	26.2	70.0
75.0				30.8	29.2	29.0	30.0	29.0	30.4	27.0	29.2	27.4	25.2	24.2	23.4	75.0
80.0				24.6	27.6	25.6	27.0	27.2	28.0	24.2	26.4	24.6	22.6	21.6	20.8	80.0
85.0				6.2	26.2	22.6	24.4	25.6	25.4	21.8	23.8	22.2	20.2	19.4	18.6	85.0
90.0					23.8	20.4	21.8	24.2	23.2	19.6	21.6	20.2	18.2	17.2	16.6	90.0
95.0					15.6	19.2	20.2	22.2	21.2	17.6	19.8	18.2	16.4	15.4	14.8	95.0
100.0					9.4	18.4	19.0	20.0	19.4	16.0	18.0	16.6	14.6	13.8	13.2	100.0
105.0						17.6	18.0	18.2	17.6	14.4	16.4	15.0	13.2	12.2	11.6	105.0
110.0						15.2	16.8	16.4	16.0	13.0	15.0	13.6	11.8	11.0	10.2	110.0
115.0						6.8	15.4	15.0	14.6	11.6	13.6	12.2	10.6	9.6	9.0	115.0
120.0							14.0	13.6	13.2	10.4	12.4	11.0	9.4	8.6	8.0	120.0
125.0							13.0	12.4	12.0	9.2	11.2	10.0	8.4	7.4	6.8	125.0
130.0							2.4	11.2	10.8	8.0	10.0	9.0	7.4	6.6	6.0	130.0
135.0								10.2	9.8	7.0	9.0	8.0	6.4	5.6	5.0	135.0
140.0									8.8	6.0	8.0	7.0	5.6	4.8	4.2	140.0
145.0									7.8	5.2	7.2	6.2	4.8	4.0	3.4	145.0
150.0									7.0	4.4	6.4	5.4	4.0	3.2	2.8	150.0
155.0									6.4	3.6	5.6	4.6	3.2	2.6	2.0	155.0
160.0										2.8	4.8	3.8	2.6			160.0
165.0										2.2	4.2	3.2				165.0
170.0											3.6	2.6				170.0
175.0											2.8					175.0

THIS CHART IS ONLY A GUIDE AND SHOULD NOT BE USED TO OPERATE THE CRANE.

The individual crane's load chart, operating instructions and other instructional plates must be read and understood prior to operating the crane

Load charts

Telescopic boom



13,3 m - 70,0 m (44 ft - 229.7 ft)



7,8 m (25.6 ft)



360°



26 t (57,300 lb)



Pounds x 1000

Feet	43.5	60.9	77.4	93.6	109.9	124.5	138.8	149.1	160.2	171.8	184.4	198.3	212.0	219.4	229.7	Feet
9.0	362.0															9.0
10.0	342.0	322.0	294.0													10.0
15.0	266.0	266.0	254.0	220.0	139.0											15.0
20.0	211.0	213.0	198.0	176.0	165.0	130.0	111.0									20.0
25.0	164.0	158.0	142.0	136.0	131.0	119.0	111.0	97.0								25.0
30.0	115.0	119.0	113.0	109.0	102.0	100.0	92.0	87.0	82.0	68.0	40.8					30.0
35.0	40.8	92.0	90.0	88.0	82.0	81.0	74.0	71.0	68.0	66.0	57.0	47.0				35.0
40.0		74.0	76.0	72.0	67.0	67.0	62.0	59.0	57.0	57.0	54.0	47.0	40.0	35.0	32.0	40.0
45.0		60.0	63.0	63.0	56.0	57.0	54.0	49.0	48.0	48.0	47.0	46.0	40.0	35.0	32.0	45.0
50.0		48.0	52.0	55.0	48.0	49.0	49.0	41.8	40.8	44.0	44.0	41.8	39.8	35.0	32.0	50.0
55.0			44.0	48.0	41.2	42.4	43.0	36.8	38.2	38.6	39.2	38.6	35.2	34.6	32.0	55.0
60.0			37.6	41.0	35.6	37.0	37.8	34.6	36.0	34.0	36.0	34.0	31.4	30.4	29.4	60.0
65.0			32.2	35.6	32.8	32.4	33.4	32.4	33.8	30.0	32.0	30.2	27.8	26.8	25.8	65.0
70.0				31.2	30.8	28.6	29.6	30.6	30.6	26.6	28.6	27.0	24.6	23.6	22.8	70.0
75.0					27.4	29.2	25.4	26.4	28.8	27.6	23.6	25.8	24.0	21.8	20.0	75.0
80.0					21.2	26.2	23.0	24.4	26.0	24.8	21.0	23.2	21.6	19.4	18.6	80.0
85.0					6.2	23.4	21.4	22.6	23.6	22.4	18.8	20.8	19.4	17.4	16.4	85.0
90.0						21.0	20.4	21.4	21.4	20.4	16.8	18.8	17.4	15.4	14.6	90.0
95.0						15.2	19.2	19.8	19.4	18.4	15.0	17.0	15.6	13.8	12.8	95.0
100.0						6.8	17.8	17.8	17.8	16.8	13.4	15.4	14.0	12.2	11.4	100.0
105.0							16.2	16.4	16.0	15.2	11.8	14.0	12.6	10.8	10.0	105.0
110.0							15.0	14.8	14.4	13.8	10.6	12.6	11.2	9.6	8.6	110.0
115.0							4.6	13.4	13.0	12.4	9.4	11.4	10.0	8.4	7.6	115.0
120.0								12.2	11.8	11.0	8.2	10.2	9.0	7.2	6.4	120.0
125.0								11.0	10.6	10.0	7.2	9.2	8.0	6.2	5.4	125.0
130.0								2.4	9.6	8.8	6.0	8.2	7.0	5.4	4.6	130.0
135.0									8.8	7.8	5.2	7.2	6.2	4.6	3.8	135.0
140.0									7.8	7.0	4.2	6.2	5.2	3.8	3.0	140.0
145.0										6.2	3.4	5.4	4.4	3.0	2.2	145.0
150.0										5.4	2.6	4.6	3.6	2.4		150.0
155.0										4.8	2.0	4.0	3.0			155.0
160.0												3.2	2.4			160.0
165.0												2.6				165.0
170.0												2.2				170.0

THIS CHART IS ONLY A GUIDE AND SHOULD NOT BE USED TO OPERATE THE CRANE.

The individual crane's load chart, operating instructions and other instructional plates must be read and understood prior to operating the crane

Load charts

Telescopic boom



13,3 m - 70,0 m (44 ft - 229.7 ft)



7,8 m (25.6 ft)



360°



21 t (46,200 lb)



Pounds x 1000

Feet	43.5	60.9	77.4	93.6	109.9	124.5	138.8	149.1	160.2	171.8	184.4	198.3	212.0	219.4	229.7	Feet
9.0	360.0															9.0
10.0	340.0	322.0	294.0													10.0
15.0	264.0	264.0	254.0	220.0	139.0											15.0
20.0	207.0	200.0	180.0	168.0	150.0	130.0	111.0									20.0
25.0	147.0	144.0	134.0	123.0	118.0	111.0	104.0	97.0								25.0
30.0	102.0	107.0	101.0	98.0	91.0	89.0	81.0	77.0	74.0	68.0	40.8					30.0
35.0	40.8	83.0	83.0	78.0	72.0	72.0	66.0	62.0	60.0	60.0	57.0	47.0				35.0
40.0		65.0	67.0	68.0	59.0	60.0	58.0	51.0	49.0	51.0	49.0	47.0	40.0	35.0	32.0	40.0
45.0		54.0	55.0	57.0	49.0	50.0	51.0	42.8	43.6	45.0	45.0	42.2	40.0	35.0	32.0	45.0
50.0		41.6	46.0	49.0	41.6	42.8	43.4	39.4	40.8	38.6	40.6	38.4	35.4	34.4	32.0	50.0
55.0			38.4	42.0	37.8	36.8	37.6	36.8	38.2	33.6	35.6	33.6	30.8	29.8	28.8	55.0
60.0			32.4	35.8	35.2	32.0	32.8	34.6	33.8	29.2	31.4	29.4	27.0	26.0	25.0	60.0
65.0			27.6	31.0	32.8	27.8	30.0	31.2	29.8	25.6	27.8	26.0	23.6	22.6	21.8	65.0
70.0			8.0	26.8	29.2	26.2	28.0	27.8	26.6	22.6	24.8	23.0	20.8	19.8	19.0	70.0
75.0				24.6	25.6	24.6	26.0	24.8	23.6	19.8	22.0	20.4	18.2	17.4	16.6	75.0
80.0				18.2	22.6	23.0	23.4	22.4	21.2	17.6	19.6	18.2	16.0	15.2	14.4	80.0
85.0				6.2	20.0	21.0	21.0	20.2	19.0	15.4	17.6	16.0	14.2	13.2	12.6	85.0
90.0					16.0	18.8	19.2	18.2	17.2	13.6	15.8	14.2	12.4	11.6	10.8	90.0
95.0					15.2	17.2	17.2	16.4	15.4	12.0	14.0	12.6	10.8	10.0	9.4	95.0
100.0					4.0	15.4	15.4	14.8	13.8	10.6	12.6	11.2	9.4	8.6	8.0	100.0
105.0						13.8	13.8	13.4	12.4	9.2	11.2	10.0	8.2	7.4	6.6	105.0
110.0						12.4	12.4	12.0	11.2	8.0	10.0	8.8	7.0	6.2	5.6	110.0
115.0						2.2	11.0	10.6	10.0	6.8	9.0	7.6	6.0	5.2	4.6	115.0
120.0							9.8	9.6	8.8	5.8	8.0	6.6	5.0	4.2	3.6	120.0
125.0							8.8	8.4	7.8	5.0	7.0	5.8	4.0	3.2	2.6	125.0
130.0								7.4	6.8	4.0	6.0	4.8	3.2	2.4		130.0
135.0								6.6	5.8	3.2	5.2	4.0	2.4			135.0
140.0								6.0	5.0	2.2	4.4	3.4				140.0
145.0									4.4		3.6	2.6				145.0
150.0									3.6		2.8					150.0
155.0									3.0		2.2					155.0

THIS CHART IS ONLY A GUIDE AND SHOULD NOT BE USED TO OPERATE THE CRANE.

The individual crane's load chart, operating instructions and other instructional plates must be read and understood prior to operating the crane

Load charts

Telescopic boom



13,3 m - 70,0 m (44 ft - 229.7 ft)



7,8 m (25.6 ft)



360°



16,5 t (36,300 lb)



Pounds x 1000

Feet	43.5	60.9	77.4	93.6	109.9	124.5	138.8	149.1	160.2	171.8	184.4	198.3	212.0	219.4	229.7	Feet
9.0	358.0															9.0
10.0	338.0	322.0	294.0													10.0
15.0	264.0	262.0	254.0	220.0	139.0											15.0
20.0	199.0	182.0	163.0	153.0	139.0	130.0	111.0									20.0
25.0	131.0	130.0	120.0	116.0	106.0	103.0	93.0	88.0								25.0
30.0	90.0	98.0	94.0	88.0	81.0	80.0	72.0	68.0	65.0	65.0	40.8					30.0
35.0	40.8	74.0	74.0	74.0	64.0	64.0	64.0	55.0	53.0	53.0	50.0	47.0				35.0
40.0		59.0	59.0	60.0	52.0	53.0	53.0	46.0	47.0	46.0	47.0	43.4	40.0	35.0	32.0	40.0
45.0		47.0	49.0	51.0	44.0	44.0	45.0	42.4	43.6	39.4	40.8	39.0	35.4	34.8	32.0	45.0
50.0		35.8	40.0	43.0	40.6	37.2	38.0	39.4	38.6	33.6	35.8	33.6	30.8	29.6	28.4	50.0
55.0			33.4	36.8	37.8	32.0	34.2	35.0	33.6	29.0	31.2	29.0	26.6	25.4	24.4	55.0
60.0			29.0	31.2	33.0	29.8	32.0	30.6	29.4	25.0	27.2	25.4	23.0	22.0	21.0	60.0
65.0			26.2	28.0	29.0	27.8	28.4	27.0	25.8	21.8	24.0	22.2	20.0	19.0	18.0	65.0
70.0				25.0	25.2	25.8	25.2	24.0	22.8	19.0	21.2	19.4	17.4	16.4	15.6	70.0
75.0				21.8	22.0	23.0	22.4	21.4	20.2	16.6	18.6	17.0	15.0	14.2	13.4	75.0
80.0				17.2	19.4	20.8	20.0	19.0	18.0	14.4	16.6	15.0	13.0	12.2	11.4	80.0
85.0				4.4	17.0	18.4	18.0	17.0	16.0	12.4	14.6	13.2	11.2	10.4	9.6	85.0
90.0					15.6	16.4	16.2	15.2	14.2	10.8	13.0	11.4	9.6	8.8	8.2	90.0
95.0					13.8	14.6	14.4	13.6	12.6	9.4	11.4	10.0	8.2	7.4	6.8	95.0
100.0						13.0	12.8	12.2	11.2	8.0	10.0	8.8	7.0	6.2	5.4	100.0
105.0						11.4	11.4	11.0	10.0	6.8	8.8	7.4	5.8	5.0	4.4	105.0
110.0						10.2	10.0	9.6	8.8	5.6	7.8	6.4	4.8	4.0	3.4	110.0
115.0							8.8	8.4	7.8	4.6	6.8	5.4	3.8	3.0	2.4	115.0
120.0							7.8	7.4	6.6	3.8	5.8	4.6	2.8	2.0		120.0
125.0							6.8	6.4	5.8	3.0	5.0	3.6	2.0			125.0
130.0								5.6	4.8	2.0	4.2	3.0				130.0
135.0								4.8	4.0		3.4	2.2				135.0
140.0								4.2	3.2		2.6					140.0
145.0									2.6							145.0
150.0									2.0							150.0

THIS CHART IS ONLY A GUIDE AND SHOULD NOT BE USED TO OPERATE THE CRANE.

The individual crane's load chart, operating instructions and other instructional plates must be read and understood prior to operating the crane

Load charts

Telescopic boom



13,3 m - 70,0 m (44 ft - 229.7 ft)



7,8 m (25.6 ft)



360°



7 t (15,400 lb)



Pounds x 1000

Feet	43.5	60.9	77.4	93.6	109.9	121.4	138.8	149.1	156.6	171.8	184.4	Feet
9.0	354.0											9.0
10.0	334.0	322.0	294.0									10.0
15.0	254.0	246.0	213.0	180.0	139.0							15.0
20.0	160.0	147.0	134.0	125.0	112.0	107.0	95.0					20.0
25.0	98.0	101.0	95.0	93.0	79.0	78.0	76.0	65.0				25.0
30.0	66.0	72.0	70.0	70.0	59.0	59.0	59.0	55.0	55.0	50.0	40.8	30.0
35.0	40.8	56.0	54.0	55.0	54.0	47.0	48.0	49.0	47.0	40.4	40.8	35.0
40.0		42.6	42.8	44.0	45.0	41.2	43.0	40.6	38.6	33.2	35.4	40.0
45.0		33.4	36.4	38.0	37.4	37.2	36.0	34.2	32.4	27.4	29.8	45.0
50.0		23.6	31.0	32.8	31.6	31.8	30.6	29.0	27.6	23.0	25.2	50.0
55.0			25.4	27.8	26.8	27.2	26.2	24.8	23.4	19.2	21.4	55.0
60.0			21.0	23.6	23.8	23.6	22.6	21.4	20.2	16.2	18.4	60.0
65.0			17.2	20.0	20.6	20.4	19.6	18.4	17.4	13.6	15.8	65.0
70.0				17.0	17.8	17.8	17.0	16.0	15.0	11.2	13.4	70.0
75.0				14.4	15.4	15.6	14.8	14.0	12.8	9.4	11.4	75.0
80.0				12.2	13.2	13.6	13.0	12.2	11.0	7.6	9.8	80.0
85.0					11.2	12.0	11.4	10.4	9.4	6.2	8.2	85.0
90.0					9.6	10.4	9.8	9.0	8.0	4.8	7.0	90.0
95.0					8.2	8.8	8.6	7.8	6.8	3.6	5.8	95.0
100.0						7.6	7.4	6.6	5.6	2.6	4.6	100.0
105.0						6.4	6.2	5.6	4.6		3.6	105.0
110.0						5.4	5.2	4.8	3.8		2.8	110.0
115.0							4.2	3.8	3.0		2.0	115.0
120.0							3.4	3.0	2.2			120.0
125.0							2.6	2.2				125.0

THIS CHART IS ONLY A GUIDE AND SHOULD NOT BE USED TO OPERATE THE CRANE.

The individual crane's load chart, operating instructions and other instructional plates must be read and understood prior to operating the crane

Load charts

Telescopic boom



13,3 m - 70,0 m (44 ft - 229.7 ft)



7,8 m (25.6 ft)



360°



0t (0 lb)



Pounds x 1000

Feet	43.5	60.9	77.4	93.6	109.9	121.4	138.8	149.1	156.6	171.8	184.4	Feet
9.0	350.0											9.0
10.0	330.0	322.0	294.0									10.0
15.0	244.0	208.0	176.0	155.0	139.0							15.0
20.0	125.0	119.0	109.0	105.0	87.0	84.0	81.0					20.0
25.0	75.0	80.0	74.0	73.0	67.0	60.0	59.0	60.0				25.0
30.0	49.0	57.0	53.0	54.0	54.0	51.0	50.0	47.0	45.0	37.6	40.0	30.0
35.0	33.0	42.2	44.0	45.0	42.6	41.8	40.2	37.6	35.6	29.8	32.2	35.0
40.0		31.2	34.8	35.6	34.8	34.0	32.6	30.6	29.0	23.8	26.2	40.0
45.0		23.6	27.8	29.2	28.6	28.2	27.0	25.4	23.8	19.2	21.4	45.0
50.0		15.2	22.4	24.0	23.8	23.6	22.6	21.0	19.8	15.4	17.8	50.0
55.0			17.8	20.0	20.0	19.8	18.8	17.6	16.4	12.4	14.6	55.0
60.0			14.2	16.8	16.8	16.8	16.0	14.8	13.8	9.8	12.2	60.0
65.0			11.0	13.8	14.2	14.2	13.4	12.4	11.4	7.8	10.0	65.0
70.0				11.2	12.0	12.0	11.4	10.4	9.4	5.8	8.2	70.0
75.0				9.2	10.0	10.2	9.6	8.8	7.8	4.2	6.4	75.0
80.0				7.2	8.2	8.6	8.0	7.2	6.2	2.8	5.0	80.0
85.0					6.6	7.2	6.6	6.0	5.0		3.8	85.0
90.0					5.4	6.0	5.4	4.8	3.8		2.8	90.0
95.0					4.2	4.8	4.4	3.8	2.8			95.0
100.0						3.8	3.4	2.8				100.0
105.0						2.8	2.6					105.0

THIS CHART IS ONLY A GUIDE AND SHOULD NOT BE USED TO OPERATE THE CRANE.

The individual crane's load chart, operating instructions and other instructional plates must be read and understood prior to operating the crane

Working range



52,4 m - 70,0 m
(173.1 ft - 229.7 ft)



41,5/21,3/29,3/37,3 m
(41.1/69.9/96.1/122.4 ft)



7,8 m
(25.6 ft)



360°



80 t
(176,300 lb)

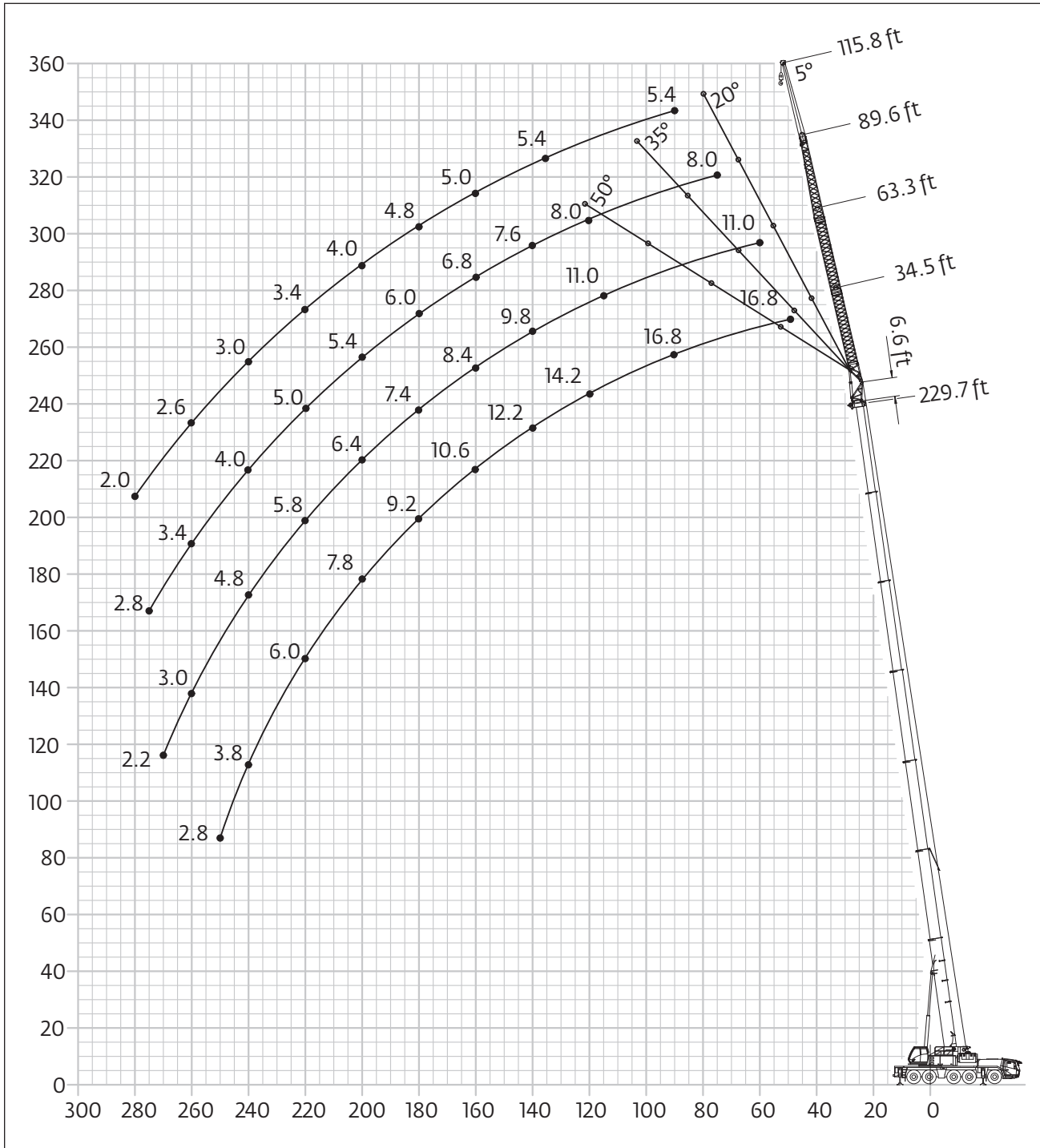

THIS CHART IS ONLY A GUIDE AND SHOULD NOT BE USED TO OPERATE THE CRANE.

The individual crane's load chart, operating instructions and other instructional plates must be read and understood prior to operating the crane

Load charts

Swingaway (hydraulic luffing)



52,4 m - 70,0 m
(173.1 ft - 229.7 ft)



12,5 m
(41.1 ft)



7,8 m
(25.6 ft)



360°



80 t (176,300 lb)



Pounds x 1000

Feet	173.1				198.3				222.3				229.7				Feet
	6.6 + 34.5				6.6 + 34.5				6.6 + 34.5				6.6 + 34.5				
	5°	*5°-20°	*20°-35°	*35°-50°	5°	*5°-20°	*20°-35°	*35°-50°	5°	*5°-20°	*20°-35°	*35°-50°	5°	*5°-20°	*20°-35°	*35°-50°	
40.0	27.6																40.0
45.0	27.6				26.2												45.0
50.0	27.0	24.8			26.2				19.4						16.8		50.0
55.0	25.8	23.6	21.4		26.2	25.8			19.4					16.8			55.0
60.0	24.6	22.4	20.6	19.8	26.2	25.6	22.8		19.4	19.4				16.8	16.8		60.0
65.0	23.2	21.4	20.0	19.2	26.2	24.8	22.8		19.4	19.4				16.8	16.8		65.0
70.0	21.8	20.6	19.2	18.6	25.6	24.0	22.4	21.2	19.4	19.4	17.8			16.8	16.8		70.0
75.0	20.6	19.6	18.6	18.0	24.8	23.0	21.6	20.8	19.4	19.4	17.8	17.8		16.8	16.8	16.6	75.0
80.0	19.6	18.6	18.0	17.4	24.0	22.0	21.0	20.4	19.4	19.0	17.8	17.4		16.8	16.8	16.6	80.0
85.0	18.6	17.6	17.2	16.8	23.2	21.2	20.2	20.0	19.2	18.4	17.6	17.2		16.8	16.8	16.4	85.0
90.0	17.6	16.8	16.4	16.4	22.2	20.4	19.6	19.4	18.8	17.8	17.2	16.8		16.8	16.8	16.2	90.0
95.0	16.8	16.2	15.8	15.8	21.2	19.8	19.0	18.8	18.0	17.2	16.8	16.4		16.8	16.2	15.8	95.0
100.0	16.0	15.4	15.2	15.2	20.2	19.0	18.4	18.2	17.4	16.6	16.2	16.0		16.4	15.8	15.2	100.0
105.0	15.4	14.8	14.6	14.6	19.6	18.4	17.8	17.6	17.0	16.2	15.8	15.6		15.8	15.2	14.8	105.0
110.0	14.8	14.2	14.0	14.0	18.8	17.8	17.2	17.0	16.4	15.6	15.2	15.2		15.2	14.6	14.2	110.0
115.0	14.2	13.6	13.4	13.4	18.2	17.2	16.6	16.6	15.8	15.0	14.8	14.8		14.6	14.0	13.6	115.0
120.0	13.6	13.0	13.0	13.0	17.4	16.6	16.2	16.2	15.2	14.6	14.2	14.2		14.2	13.6	13.2	120.0
125.0	13.0	12.6	12.4	12.4	16.8	16.0	15.6	15.6	14.8	14.2	13.8	13.8		13.6	13.0	12.8	125.0
130.0	12.4	12.0	12.0	12.0	16.2	15.6	15.2	15.2	14.2	13.6	13.4	13.4		13.0	12.6	12.4	130.0
135.0	11.8	11.6	11.6	11.6	15.8	15.2	14.8	14.8	13.8	13.2	13.0	13.0		12.6	12.2	12.0	135.0
140.0	11.4	11.2	11.2	11.2	15.2	14.6	14.4	14.4	13.2	12.8	12.6	12.6		12.2	11.8	11.6	140.0
145.0	11.0	10.8	10.8	10.8	14.8	14.2	14.0	14.0	12.8	12.4	12.2	12.2		11.8	11.4	11.2	145.0
150.0	10.6	10.4	10.4	10.4	14.2	13.8	13.6	13.6	12.4	12.0	12.0	12.0		11.4	11.0	10.8	150.0
155.0	10.2	10.0	10.0		13.8	13.4	13.4	13.4	12.0	11.6	11.6	11.6		11.0	10.6	10.6	155.0
160.0	9.8	9.8	9.8		13.4	13.0	13.0	13.0	11.6	11.4	11.2	11.2		10.6	10.4	10.2	160.0
165.0	9.4	9.4	9.4		13.0	12.8	12.6	12.6	11.2	11.0	11.0	11.0		10.2	10.0	10.0	165.0
170.0	9.2	9.0	9.0		12.2	12.2	12.2	12.2	10.8	10.6	10.6	10.6		10.0	9.8	9.6	170.0
175.0	8.8	8.8	8.8		11.6		11.8		10.2	10.2	10.4	10.4		9.6	9.4	9.4	175.0
180.0	8.6	8.6			10.8		11.2		9.8	9.8	10.0	10.2		9.2	9.2	9.2	180.0
185.0	8.2	8.2			10.2		10.6		9.2	9.2	9.6	9.6		9.0	8.8	8.8	185.0
190.0	8.0	8.0			9.6		10.0		8.8	8.8	9.0	9.2		8.6	8.6	8.6	190.0
195.0	7.8	7.8			9.0		9.4		8.2	8.2	8.6			8.2	8.2	8.4	195.0
200.0	7.6	6.0			8.4		8.8		7.8	7.8	8.0			7.8	7.8	8.0	200.0
205.0					7.6				7.4	7.4	7.6			7.4	7.4	7.6	205.0
210.0					7.0				7.0	7.0	7.2			6.8	6.8	7.2	210.0
215.0					6.2				6.4	6.4	6.6			6.4	6.4	6.6	215.0
220.0					5.6				6.0	6.0	6.2			6.0	6.0	6.2	220.0
225.0					2.4				5.4	5.4				5.6	5.6	5.8	225.0
230.0									4.8	4.8				5.0	5.0		230.0
235.0									4.2	4.2				4.4	4.4		235.0
240.0									3.6	3.6				3.8	3.8		240.0
245.0									2.6	2.6				3.2	3.2		245.0
250.0														2.8	2.8		250.0

* Luffing under load

THIS CHART IS ONLY A GUIDE AND SHOULD NOT BE USED TO OPERATE THE CRANE.

The individual crane's load chart, operating instructions and other instructional plates must be read and understood prior to operating the crane

Load charts

Swingaway (hydraulic luffing)



52,4 m - 70,0 m
(173.1 ft - 229.7 ft)



21,3 m
(69.9 ft)



7,8 m
(25.6 ft)



360°



80 t (176,300 lb)



Pounds x 1000

Feet	173.1 6.6 + 63.3				198.3 6.6 + 63.3				222.3 6.6 + 63.3				229.7 6.6 + 63.3				Feet	
	5°	*5°-20°	*20°-35°	*35°-50°	5°	*5°-20°	*20°-35°	*35°-50°	5°	*5°-20°	*20°-35°	*35°-50°	5°	*5°-20°	*20°-35°	*35°-50°		
50.0	14.8																50.0	
55.0	14.6				14.2												55.0	
60.0	14.6				14.2				12.2						11.0		60.0	
65.0	14.4				14.0				12.2						11.0		65.0	
70.0	14.4	13.4			14.0	13.4			12.2						11.0		70.0	
75.0	14.2	13.2			13.8	13.2			12.2	11.6					11.0		75.0	
80.0	14.0	13.0	11.4		13.8	13.2			12.2	11.6				11.0	11.0		80.0	
85.0	14.0	12.6	11.2		13.8	13.0			12.0	11.6				11.0	11.0		85.0	
90.0	13.6	12.4	11.0	10.0	13.6	12.6	11.2		12.0	11.6				11.0	11.0		90.0	
95.0	13.2	12.2	10.8	10.0	13.6	12.4	11.0	10.0	12.0	11.6	10.8			11.0	11.0	10.8	95.0	
100.0	13.0	11.8	10.6	10.0	13.4	12.2	10.8	10.0	12.0	11.6	10.8	10.0		11.0	11.0	10.8	9.8	100.0
105.0	12.4	11.4	10.6	9.8	13.4	12.0	10.8	10.0	12.0	11.6	10.6	9.8		11.0	11.0	10.6	9.8	105.0
110.0	12.0	11.0	10.4	9.8	13.2	11.8	10.6	9.8	12.0	11.4	10.4	9.8		11.0	10.8	10.4	9.8	110.0
115.0	11.4	10.8	10.2	9.6	13.2	11.6	10.4	9.8	11.8	11.2	10.4	9.8		11.0	10.6	10.2	9.8	115.0
120.0	11.0	10.4	9.8	9.6	13.0	11.4	10.4	9.8	11.8	10.8	10.2	9.6		10.8	10.4	10.0	9.6	120.0
125.0	10.6	10.0	9.6	9.4	12.8	11.4	10.2	9.6	11.4	10.6	10.0	9.6		10.8	10.2	9.8	9.6	125.0
130.0	10.2	9.8	9.4	9.2	12.6	11.2	10.2	9.6	11.2	10.4	9.8	9.6		10.4	10.0	9.6	9.4	130.0
135.0	9.8	9.4	9.2	9.0	12.2	11.0	10.0	9.6	10.8	10.2	9.6	9.4		10.2	9.6	9.4	9.2	135.0
140.0	9.4	9.2	9.0	8.8	11.8	10.8	10.0	9.6	10.4	10.0	9.4	9.2		9.8	9.4	9.2	9.0	140.0
145.0	9.0	8.8	8.6	8.6	11.4	10.8	10.0	9.6	10.2	9.6	9.2	9.2		9.4	9.0	8.8	8.8	145.0
150.0	8.6	8.4	8.4	8.4	11.0	10.6	9.8	9.4	9.8	9.4	9.0	9.0		9.0	8.8	8.6	8.6	150.0
155.0	8.4	8.2	8.2	8.2	10.8	10.2	9.8	9.4	9.6	9.2	8.8	8.8		8.8	8.4	8.4	8.4	155.0
160.0	8.0	7.8	7.8	8.0	10.4	10.0	9.6	9.4	9.2	8.8	8.6	8.6		8.4	8.2	8.0	8.0	160.0
165.0	7.6	7.6	7.6	7.6	10.0	9.6	9.6	9.4	9.0	8.6	8.6	8.6		8.2	8.0	7.8	7.8	165.0
170.0	7.4	7.4	7.4	7.4	9.8	9.4	9.4	9.4	8.6	8.4	8.4	8.4		8.0	7.6	7.6	7.6	170.0
175.0	7.2	7.2	7.2	7.2	9.6	9.2	9.2	9.2	8.4	8.2	8.0	8.0		7.6	7.4	7.4	7.4	175.0
180.0	6.8	6.8	6.8	7.0	9.2	9.0	9.0	9.0	8.2	7.8	7.8	7.8		7.4	7.2	7.2	7.2	180.0
185.0	6.6	6.6	6.6		9.0	8.8	8.8	8.8	7.8	7.6	7.6	7.6		7.2	7.0	7.0	7.0	185.0
190.0	6.4	6.4	6.4		8.8	8.6	8.6	8.6	7.6	7.4	7.4	7.4		7.0	6.8	6.8	6.8	190.0
195.0	6.2	6.2	6.2		8.6	8.4	8.4	8.4	7.4	7.2	7.2	7.4		6.6	6.6	6.6	6.6	195.0
200.0	6.0	6.0	6.0		8.2	8.2	8.2	8.2	7.2	7.0	7.0	7.2		6.4	6.4	6.4	6.4	200.0
205.0	5.8	5.8	5.8		8.0	8.0	8.0		7.0	6.8	6.8	7.0		6.2	6.2	6.2	6.2	205.0
210.0	5.6	5.6			7.8	7.8	7.8		6.8	6.8	6.8	6.8		6.0	6.0	6.0	6.0	210.0
215.0	5.4	5.4			7.6	7.6	7.6		6.6	6.6	6.6	6.6		6.0	5.8	5.8	6.0	215.0
220.0	5.2	5.2			7.2	7.2	7.4		6.4	6.4	6.4			5.8	5.6	5.6	5.8	220.0
225.0	5.2	5.2			6.8	6.8	7.0		6.0	6.0	6.2			5.6	5.6	5.6		225.0
230.0	5.0	2.2			6.2	6.2			5.8	5.8	6.0			5.4	5.4	5.4		230.0
235.0					5.6	5.6			5.4	5.4	5.8			5.2	5.2	5.2		235.0
240.0					5.0	5.0			5.0	5.0	5.4			4.8	4.8	5.0		240.0
245.0					4.4	4.4			4.4	4.4	4.8			4.6	4.6	5.0		245.0
250.0					4.0	3.4			4.0	4.0	4.4			4.0	4.0	4.4		250.0
255.0									3.4	3.4	3.8			3.6	3.6	4.0		255.0
260.0									3.0	3.0				3.0	3.0	3.4		260.0
265.0									2.4	2.4				2.6	2.6			265.0
270.0									2.0	2.0				2.2	2.2			270.0

* Luffing under load

THIS CHART IS ONLY A GUIDE AND SHOULD NOT BE USED TO OPERATE THE CRANE.

The individual crane's load chart, operating instructions and other instructional plates must be read and understood prior to operating the crane

Load charts

Swingaway (hydraulic luffing)



52,4 m - 70,0 m
(173.1 ft - 229.7 ft)



12,5 m
(41.1 ft)



7,8 m
(25.6 ft)



360°



50 t (110,200 lb)



Pounds x 1000

Feet	173.1 6.6 + 34.5				198.3 6.6 + 34.5				222.3 6.6 + 34.5				229.7 6.6 + 34.5				Feet
	5°	*5°-20°	*20°-35°	*35°-50°	5°	*5°-20°	*20°-35°	*35°-50°	5°	*5°-20°	*20°-35°	*35°-50°	5°	*5°-20°	*20°-35°	*35°-50°	
40.0	27.6																40.0
45.0	27.6				26.2												45.0
50.0	27.0	24.8			26.2				19.4						16.8		50.0
55.0	25.8	23.6	21.4		26.2	25.8			19.4					16.8			55.0
60.0	24.6	22.4	20.6	19.8	26.2	25.6	22.8		19.4	19.4				16.8	16.8		60.0
65.0	23.2	21.4	20.0	19.2	26.2	24.8	22.8		19.4	19.4				16.8	16.8		65.0
70.0	21.8	20.6	19.2	18.6	25.6	24.0	22.4	21.2	19.4	19.4	17.8			16.8	16.8		70.0
75.0	20.6	19.6	18.6	18.0	24.8	23.0	21.6	20.8	19.4	19.4	17.8	17.8		16.8	16.8	16.6	75.0
80.0	19.6	18.6	18.0	17.4	24.0	22.0	21.0	20.4	19.4	19.0	17.8	17.4		16.8	16.8	16.6	80.0
85.0	18.6	17.6	17.2	16.8	23.2	21.2	20.2	20.0	19.2	18.4	17.6	17.2		16.8	16.8	16.4	85.0
90.0	17.6	16.8	16.4	16.4	22.2	20.4	19.6	19.4	18.8	17.8	17.2	16.8		16.8	16.8	16.2	90.0
95.0	16.8	16.2	15.8	15.8	21.2	19.8	19.0	18.8	18.0	17.2	16.8	16.4		16.8	16.2	15.8	95.0
100.0	16.0	15.4	15.2	15.2	20.2	19.0	18.4	18.2	17.4	16.6	16.2	16.0		16.4	15.8	15.2	100.0
105.0	15.4	14.8	14.6	14.6	19.6	18.4	17.8	17.6	17.0	16.2	15.8	15.6		15.8	15.2	14.8	105.0
110.0	14.8	14.2	14.0	14.0	18.0	17.8	17.2	17.0	16.4	15.6	15.2	15.2		15.2	14.6	14.2	110.0
115.0	14.2	13.6	13.4	13.4	16.4	16.4	16.6	16.6	15.8	15.0	14.8	14.8		14.6	14.0	13.6	115.0
120.0	13.6	13.0	13.0	13.0	14.8	14.8	16.2	16.2	14.8	14.6	14.2	14.2		14.2	13.6	13.2	120.0
125.0	13.0	12.6	12.4	12.4	13.4	13.4	14.8	15.4	13.4	13.4	13.8	13.8		13.6	13.0	12.8	125.0
130.0	12.4	12.0	12.0	12.0	12.2	12.2	13.4	14.0	12.2	12.2	13.2	13.4		12.2	12.2	12.4	130.0
135.0	11.8	11.6	11.6	11.6	11.0	11.0	12.2	12.8	11.0	11.0	12.0	12.6		11.2	11.2	12.0	135.0
140.0	11.4	11.2	11.2	11.2	10.0	10.0	11.0	11.6	10.0	10.0	10.8	11.4		10.0	10.0	10.8	140.0
145.0	11.0	10.8	10.8	10.8	9.0	9.0	10.0	10.4	9.0	9.0	9.8	10.2		9.0	9.0	9.8	145.0
150.0	10.6	10.4	10.4	10.4	8.0	8.0	9.0	9.4	8.0	8.0	8.8	9.2		8.0	8.0	8.8	150.0
155.0	10.2	10.0	10.0		7.0	7.0	8.0	8.4	7.2	7.2	7.8	8.2		7.2	7.2	7.8	155.0
160.0	9.8	9.8	9.8		6.2	6.2	7.0	7.4	6.2	6.2	7.0	7.4		6.4	6.4	7.0	160.0
165.0	9.2	9.2	9.4		5.2	5.2	6.2	6.4	5.6	5.6	6.2	6.6		5.6	5.6	6.2	165.0
170.0	8.4	8.4	8.8		4.4	4.4	5.2	5.6	4.8	4.8	5.4	5.8		4.8	4.8	5.4	170.0
175.0	7.6	7.6	8.0		3.6	3.6	4.4		4.0	4.0	4.6	5.0		4.2	4.2	4.8	175.0
180.0	6.8	6.8			2.8	2.8	3.6		3.4	3.4	3.8	4.2		3.6	3.6	4.0	180.0
185.0	6.2	6.2			2.2	2.2	2.8		2.6	2.6	3.2	3.4		2.8	2.8	3.4	185.0
190.0	5.4	5.4					2.2				2.4	2.6		2.2	2.2	2.6	190.0
195.0	4.8	4.8															195.0
200.0	4.2	4.4														2.2	200.0

* Luffing under load

THIS CHART IS ONLY A GUIDE AND SHOULD NOT BE USED TO OPERATE THE CRANE.

The individual crane's load chart, operating instructions and other instructional plates must be read and understood prior to operating the crane

Load charts

Swingaway (hydraulic luffing)



52,4 m - 70,0 m
(173.1 ft - 229.7 ft)



21,3 m
(69.9 ft)



7,8 m
(25.6 ft)



360°



50 t (110,200 lb)



Pounds x 1000

Feet	173.1 6.6 + 63.3				198.3 6.6 + 63.3				222.3 6.6 + 63.3				229.7 6.6 + 63.3				Feet	
	5°	*5°-20°	*20°-35°	*35°-50°	5°	*5°-20°	*20°-35°	*35°-50°	5°	*5°-20°	*20°-35°	*35°-50°	5°	*5°-20°	*20°-35°	*35°-50°		
50.0	14.8																50.0	
55.0	14.6				14.2												55.0	
60.0	14.6				14.2				12.2					11.0			60.0	
65.0	14.4				14.0				12.2					11.0			65.0	
70.0	14.4	13.4			14.0	13.4			12.2					11.0			70.0	
75.0	14.2	13.2			13.8	13.2			12.2	11.6				11.0			75.0	
80.0	14.0	13.0	11.4		13.8	13.2			12.2	11.6				11.0	11.0		80.0	
85.0	14.0	12.6	11.2		13.8	13.0			12.0	11.6				11.0	11.0		85.0	
90.0	13.6	12.4	11.0	10.0	13.6	12.6	11.2		12.0	11.6				11.0	11.0		90.0	
95.0	13.2	12.2	10.8	10.0	13.6	12.4	11.0	10.0	12.0	11.6	10.8			11.0	11.0	10.8	95.0	
100.0	13.0	11.8	10.6	10.0	13.4	12.2	10.8	10.0	12.0	11.6	10.8	10.0		11.0	11.0	10.8	100.0	
105.0	12.4	11.4	10.6	9.8	13.4	12.0	10.8	10.0	12.0	11.6	10.6	9.8		11.0	11.0	10.6	105.0	
110.0	12.0	11.0	10.4	9.8	13.2	11.8	10.6	9.8	12.0	11.4	10.4	9.8		11.0	10.8	10.4	110.0	
115.0	11.4	10.8	10.2	9.6	13.2	11.6	10.4	9.8	11.8	11.2	10.4	9.8		11.0	10.6	10.2	115.0	
120.0	11.0	10.4	9.8	9.6	13.0	11.4	10.4	9.8	11.8	10.8	10.2	9.6		10.8	10.4	10.0	120.0	
125.0	10.6	10.0	9.6	9.4	12.8	11.4	10.2	9.6	11.4	10.6	10.0	9.6		10.8	10.2	9.8	125.0	
130.0	10.2	9.8	9.4	9.2	12.6	11.2	10.2	9.6	11.2	10.4	9.8	9.6		10.4	10.0	9.6	130.0	
135.0	9.8	9.4	9.2	9.0	12.2	11.0	10.0	9.6	10.8	10.2	9.6	9.4		10.2	9.6	9.4	135.0	
140.0	9.4	9.2	9.0	8.8	11.6	10.8	10.0	9.6	10.4	10.0	9.4	9.2		9.8	9.4	9.2	140.0	
145.0	9.0	8.8	8.6	8.6	10.6	10.6	10.0	9.6	10.0	9.6	9.2	9.2		9.4	9.0	8.8	145.0	
150.0	8.6	8.4	8.4	8.4	9.6	9.6	9.8	9.4	9.2	9.2	9.0	9.0		9.0	8.8	8.6	150.0	
155.0	8.4	8.2	8.2	8.2	8.6	8.6	9.8	9.4	8.2	8.2	8.8	8.8		8.2	8.2	8.4	155.0	
160.0	8.0	7.8	7.8	8.0	7.8	7.8	9.0	9.4	7.4	7.4	8.6	8.6		7.4	7.4	8.0	160.0	
165.0	7.6	7.6	7.6	7.6	7.0	7.0	8.2	9.2	6.6	6.6	7.8	8.6		6.6	6.6	7.8	165.0	
170.0	7.4	7.4	7.4	7.4	6.2	6.2	7.4	8.2	6.0	6.0	7.0	8.0		6.0	6.0	7.2	170.0	
175.0	7.2	7.2	7.2	7.2	5.6	5.6	6.6	7.4	5.2	5.2	6.4	7.2		5.2	5.2	6.4	175.0	
180.0	6.8	6.8	6.8	7.0	4.8	4.8	5.8	6.6	4.6	4.6	5.6	6.4		4.6	4.6	5.6	180.0	
185.0	6.6	6.6	6.6		4.2	4.2	5.2	5.8	4.0	4.0	5.0	5.6		4.0	4.0	5.0	185.0	
190.0	6.4	6.4	6.4		3.4	3.4	4.4	5.0	3.4	3.4	4.2	5.0		3.4	3.4	4.4	190.0	
195.0	6.2	6.2	6.2		2.8	2.8	3.8	4.2	2.8	2.8	3.6	4.4		2.8	2.8	3.8	195.0	
200.0	5.8	5.8	6.0		2.2	2.2	3.0	3.6	2.2	2.2	3.0	3.6		2.2	2.2	3.2	200.0	
205.0	5.2	5.2	5.6				2.4				2.4	3.0				2.6	3.2	205.0
210.0	4.6	4.6										2.4				2.0	2.6	210.0
215.0	4.2	4.2														2.0		215.0
220.0	3.6	3.6																220.0
225.0	3.2	3.2																225.0
230.0	2.8	2.2																230.0

* Luffing under load

THIS CHART IS ONLY A GUIDE AND SHOULD NOT BE USED TO OPERATE THE CRANE.

The individual crane's load chart, operating instructions and other instructional plates must be read and understood prior to operating the crane

Load charts

Swingaway (hydraulic luffing)



52,4 m - 70,0 m
(173.1 ft - 229.7 ft)



12,5 m
(41.1 ft)



7,8 m
(25.6 ft)



360°



35,5 t (78,200 lb)



Pounds x 1000

Feet	173.1 6.6 + 34.5				198.3 6.6 + 34.5				222.3 6.6 + 34.5				229.7 6.6 + 34.5				Feet
	5°	*5°-20°	*20°-35°	*35°-50°	5°	*5°-20°	*20°-35°	*35°-50°	5°	*5°-20°	*20°-35°	*35°-50°	5°	*5°-20°	*20°-35°	*35°-50°	
40.0	27.6																40.0
45.0	27.6				26.2												45.0
50.0	27.0	24.8			26.2				19.4						16.8		50.0
55.0	25.8	23.6	21.4		26.2	25.8			19.4					16.8			55.0
60.0	24.6	22.4	20.6	19.8	26.2	25.6	22.8		19.4	19.4				16.8	16.8		60.0
65.0	23.2	21.4	20.0	19.2	26.2	24.8	22.8		19.4	19.4				16.8	16.8		65.0
70.0	21.8	20.6	19.2	18.6	25.6	24.0	22.4	21.2	19.4	19.4	17.8			16.8	16.8		70.0
75.0	20.6	19.6	18.6	18.0	24.8	23.0	21.6	20.8	19.4	19.4	17.8	17.8		16.8	16.8	16.6	75.0
80.0	19.6	18.6	18.0	17.4	22.2	22.0	21.0	20.4	19.4	19.0	17.8	17.4		16.8	16.8	16.6	80.0
85.0	18.6	17.6	17.2	16.8	19.8	19.8	20.2	20.0	19.2	18.4	17.6	17.2		16.8	16.8	16.4	85.0
90.0	17.6	16.8	16.4	16.4	17.6	17.6	19.4	19.4	17.4	17.4	17.2	16.8		16.8	16.8	16.2	90.0
95.0	16.8	16.2	15.8	15.8	15.6	15.6	17.4	18.6	15.6	15.6	16.8	16.4		15.6	15.6	15.8	95.0
100.0	16.0	15.4	15.2	15.2	13.8	13.8	15.6	16.6	13.8	13.8	15.2	16.0		13.8	13.8	15.2	100.0
105.0	15.4	14.8	14.6	14.6	12.2	12.2	13.8	14.8	12.2	12.2	13.4	14.6		12.2	12.2	13.6	105.0
110.0	14.8	14.2	14.0	14.0	10.8	10.8	12.4	13.2	10.8	10.8	12.0	13.0		10.8	10.8	12.0	110.0
115.0	14.2	13.6	13.4	13.4	9.4	9.4	10.8	11.8	9.6	9.6	10.6	11.4		9.6	9.6	10.6	115.0
120.0	12.8	12.8	13.0	13.0	8.2	8.2	9.6	10.4	8.4	8.4	9.4	10.2		8.4	8.4	9.4	120.0
125.0	11.6	11.6	12.4	12.4	7.2	7.2	8.4	9.2	7.2	7.2	8.2	9.0		7.2	7.2	8.2	125.0
130.0	10.6	10.6	11.6	12.0	6.0	6.0	7.2	8.0	6.2	6.2	7.0	7.8		6.2	6.2	7.2	130.0
135.0	9.6	9.6	10.4	11.0	5.2	5.2	6.2	6.8	5.2	5.2	6.0	6.8		5.4	5.4	6.2	135.0
140.0	8.6	8.6	9.4	9.8	4.2	4.2	5.2	5.8	4.4	4.4	5.2	5.8		4.4	4.4	5.2	140.0
145.0	7.8	7.8	8.6	9.0	3.4	3.4	4.4	4.8	3.6	3.6	4.2	4.8		3.6	3.6	4.4	145.0
150.0	6.8	6.8	7.6		2.6	2.6	3.6	4.0	2.8	2.8	3.4	4.0		2.8	2.8	3.6	150.0
155.0	6.0	6.0	6.6				2.8	3.2	2.0	2.0	2.6	3.2		2.2	2.2	2.8	155.0
160.0	5.2	5.2	5.8				2.0	2.4				2.4				2.0	160.0
165.0	4.4	4.4	5.0														165.0
170.0	3.8	3.8	4.2														170.0
175.0	3.0	3.0	3.6														175.0
180.0	2.4	2.4															180.0

* Luffing under load

THIS CHART IS ONLY A GUIDE AND SHOULD NOT BE USED TO OPERATE THE CRANE.

The individual crane's load chart, operating instructions and other instructional plates must be read and understood prior to operating the crane



52,4 m - 70,0 m
(173.1 ft - 229.7 ft)



21,3 m
(69.9 ft)



7,8 m
(25.6 ft)



360°



35,5 t (78,200 lb)



Pounds x 1000

Feet	173.1 6.6 + 63.3				198.3 6.6 + 63.3				222.3 6.6 + 63.3				229.7 6.6 + 63.3				Feet	
	5°	*5°-20°	*20°-35°	*35°-50°	5°	*5°-20°	*20°-35°	*35°-50°	5°	*5°-20°	*20°-35°	*35°-50°	5°	*5°-20°	*20°-35°	*35°-50°		
50.0	14.8																50.0	
55.0	14.6				14.2												55.0	
60.0	14.6				14.2				12.2						11.0		60.0	
65.0	14.4				14.0				12.2						11.0		65.0	
70.0	14.4	13.4			14.0	13.4			12.2						11.0		70.0	
75.0	14.2	13.2			13.8	13.2			12.2	11.6					11.0		75.0	
80.0	14.0	13.0	11.4		13.8	13.2			12.2	11.6				11.0	11.0		80.0	
85.0	14.0	12.6	11.2		13.8	13.0			12.0	11.6				11.0	11.0		85.0	
90.0	13.6	12.4	11.0	10.0	13.6	12.6	11.2		12.0	11.6				11.0	11.0		90.0	
95.0	13.2	12.2	10.8	10.0	13.6	12.4	11.0	10.0	12.0	11.6	10.8			11.0	11.0	10.8	95.0	
100.0	13.0	11.8	10.6	10.0	13.4	12.2	10.8	10.0	12.0	11.6	10.8	10.0		11.0	11.0	10.8	9.8	100.0
105.0	12.4	11.4	10.6	9.8	13.4	12.0	10.8	10.0	12.0	11.6	10.6	9.8		11.0	11.0	10.6	9.8	105.0
110.0	12.0	11.0	10.4	9.8	12.6	11.8	10.6	9.8	12.0	11.4	10.4	9.8		11.0	10.8	10.4	9.8	110.0
115.0	11.4	10.8	10.2	9.6	11.2	11.2	10.4	9.8	10.8	10.8	10.4	9.8		10.6	10.6	10.2	9.8	115.0
120.0	11.0	10.4	9.8	9.6	10.0	10.0	10.4	9.8	9.6	9.6	10.2	9.6		9.6	9.6	10.0	9.6	120.0
125.0	10.6	10.0	9.6	9.4	8.8	8.8	10.2	9.6	8.4	8.4	10.0	9.6		8.4	8.4	9.8	9.6	125.0
130.0	10.2	9.8	9.4	9.2	7.8	7.8	9.6	9.6	7.4	7.4	9.2	9.6		7.4	7.4	9.2	9.4	130.0
135.0	9.8	9.4	9.2	9.0	6.8	6.8	8.4	9.6	6.4	6.4	8.2	9.4		6.4	6.4	8.2	9.2	135.0
140.0	9.4	9.2	9.0	8.8	6.0	6.0	7.6	8.8	5.6	5.6	7.2	8.4		5.6	5.6	7.2	8.6	140.0
145.0	9.0	8.8	8.6	8.6	5.2	5.2	6.6	7.8	4.8	4.8	6.2	7.4		4.8	4.8	6.2	7.6	145.0
150.0	8.4	8.4	8.4	8.4	4.4	4.4	5.6	6.8	4.0	4.0	5.4	6.6		4.0	4.0	5.4	6.6	150.0
155.0	7.6	7.6	8.2	8.2	3.6	3.6	4.8	6.0	3.2	3.2	4.6	5.6		3.2	3.2	4.6	5.8	155.0
160.0	6.8	6.8	7.8	8.0	2.8	2.8	4.2	5.0	2.6	2.6	3.8	4.8		2.6	2.6	3.8	5.0	160.0
165.0	6.2	6.2	7.0	7.6	2.2	2.2	3.4	4.2			3.2	4.2				3.2	4.2	165.0
170.0	5.4	5.4	6.4	7.0			2.6	3.6			2.4	3.4				2.6	3.4	170.0
175.0	4.8	4.8	5.6	6.2			2.0	2.8				2.6					2.8	175.0
180.0	4.2	3.6	5.0	5.4				2.2				2.0					2.0	180.0
185.0	3.6	3.0	4.2															185.0
190.0	3.0	2.4	3.6															190.0
195.0	2.4		3.0															195.0
200.0			2.4															200.0

* Luffing under load

THIS CHART IS ONLY A GUIDE AND SHOULD NOT BE USED TO OPERATE THE CRANE.

The individual crane's load chart, operating instructions and other instructional plates must be read and understood prior to operating the crane



52,4 m - 70,0 m
(173.1 ft - 229.7 ft)



12,5 m
(41.1 ft)



7,8 m
(25.6 ft)



360°



21 t (46,200 lb)



Pounds x 1000

Feet ft	173.1 6.6 + 34.5				198.3 6.6 + 34.5				222.3 6.6 + 34.5				229.7 6.6 + 34.5				Feet
	5°	*5°-20°	*20°-35°	*35°-50°	5°	*5°-20°	*20°-35°	*35°-50°	5°	*5°-20°	*20°-35°	*35°-50°	5°	*5°-20°	*20°-35°	*35°-50°	
40.0	27.6																40.0
45.0	27.6				26.2												45.0
50.0	27.0	24.8			26.2				19.4				16.8				50.0
55.0	25.8	23.6	21.4		26.2	25.8			19.4				16.8				55.0
60.0	24.6	22.4	20.6	19.8	23.2	23.2	22.8		19.4	19.4			16.8	16.8			60.0
65.0	23.2	21.4	20.0	19.2	20.0	20.0	22.6		19.4	19.4			16.8	16.8			65.0
70.0	21.8	20.6	19.2	18.6	17.2	17.2	19.6	21.2	16.8	16.8	17.8		16.8	16.8			70.0
75.0	20.0	19.6	18.6	18.0	14.8	14.8	17.0	18.6	14.4	14.4	16.4	17.8	14.4	14.4	16.4		75.0
80.0	17.6	17.6	18.0	17.4	12.6	12.6	14.6	16.2	12.4	12.4	14.2	15.6	12.4	12.4	14.2	15.6	80.0
85.0	15.6	15.6	17.2	16.8	10.6	10.6	12.6	14.0	10.6	10.6	12.2	13.6	10.6	10.6	12.2	13.6	85.0
90.0	13.8	13.8	15.4	16.4	9.0	9.0	10.8	12.2	9.0	9.0	10.4	11.8	9.0	9.0	10.4	11.8	90.0
95.0	12.2	12.2	13.6	14.6	7.4	7.4	9.2	10.4	7.4	7.4	8.8	10.0	7.6	7.6	9.0	10.0	95.0
100.0	10.8	10.8	12.2	13.0	6.0	6.0	7.8	8.8	6.2	6.2	7.4	8.6	6.2	6.2	7.6	8.6	100.0
105.0	9.4	9.4	10.8	11.6	4.8	4.8	6.4	7.4	4.8	4.8	6.2	7.2	5.0	5.0	6.2	7.2	105.0
110.0	8.2	8.2	9.4	10.2	3.6	3.6	5.2	6.0	3.8	3.8	5.0	5.8	3.8	3.8	5.0	6.0	110.0
115.0	7.2	7.2	8.4	9.0	2.6	2.6	4.0	4.8	2.8	2.8	3.8	4.8	2.8	2.8	4.0	4.8	115.0
120.0	6.2	6.2	7.2	7.8			3.0	3.8			2.8	3.6			3.0	3.8	120.0
125.0	5.2	5.2	6.2	6.8			2.0	2.8				2.6			2.0	2.8	125.0
130.0	4.4	4.4	5.4														130.0
135.0	3.6	3.6	4.4														135.0
140.0	2.8	2.8	3.6														140.0
145.0	2.2	2.2	3.0														145.0
150.0			2.2														150.0

* Luffing under load

THIS CHART IS ONLY A GUIDE AND SHOULD NOT BE USED TO OPERATE THE CRANE.

The individual crane's load chart, operating instructions and other instructional plates must be read and understood prior to operating the crane

Load charts

Swingaway (hydraulic luffing)



52,4 m - 70,0 m
(173.1 ft - 229.7 ft)



21,3 m
(69.9 ft)



7,8 m
(25.6 ft)



360°



21 t (46,200 lb)



Pounds x 1000

Feet	173.1 6.6 + 63.3				198.3 6.6 + 63.3				222.3 6.6 + 63.3				229.7 6.6 + 63.3				Feet
	5°	*5°-20°	*20°-35°	*35°-50°	5°	*5°-20°	*20°-35°	*35°-50°	5°	*5°-20°	*20°-35°	*35°-50°	5°	*5°-20°	*20°-35°	*35°-50°	
50.0	14.8																50.0
55.0	14.6				14.2												55.0
60.0	14.6				14.2												60.0
65.0	14.4				14.0												65.0
70.0	14.4	13.4			14.0	13.4											70.0
75.0	14.2	13.2			13.8	13.2											75.0
80.0	14.0	13.0	11.4		13.8	13.2	11.2										80.0
85.0	14.0	12.6	11.2		12.6	12.6	11.0										85.0
90.0	13.6	12.4	11.0	10.0	10.8	10.8	10.4										90.0
95.0	13.2	12.2	10.8	10.0	9.4	9.4	9.0	10.0									95.0
100.0	12.4	11.8	10.6	10.0	8.0	8.0	7.8	10.0									100.0
105.0	11.0	11.0	10.6	9.8	6.8	6.8	6.6	10.0									105.0
110.0	9.8	9.8	10.4	9.8	5.6	5.6	5.4	9.6									110.0
115.0	8.8	8.8	10.2	9.6	4.6	4.6	4.4	8.4									115.0
120.0	7.6	7.6	9.2	9.6	3.6	3.6	3.6	7.2									120.0
125.0	6.8	6.8	8.2	9.4	2.6	2.6	2.6	6.0									125.0
130.0	6.0	6.0	7.2	8.4				5.0									130.0
135.0	5.2	5.2	6.4	7.4				4.0									135.0
140.0	4.4	4.4	5.6	6.6				3.2									140.0
145.0	3.6	3.6	4.8	5.8				2.4									145.0
150.0	3.0	3.0	4.0	5.0													150.0
155.0	2.4	2.4	3.4	4.2													155.0
160.0			2.8	3.4													160.0
165.0			2.2	2.8													165.0
170.0			2.2														170.0

* Luffing under load

THIS CHART IS ONLY A GUIDE AND SHOULD NOT BE USED TO OPERATE THE CRANE.

The individual crane's load chart, operating instructions and other instructional plates must be read and understood prior to operating the crane

Load charts

Swingaway (hydraulic luffing)



52,4 m - 70,0 m
(173.1 ft - 229.7 ft)



29,3 m
(96.1 ft)



7,8 m
(25.6 ft)



360°



80 t (176,300 lb)



Pounds x 1000

Feet	173.1 6.6 + 89.5				198.3 6.6 + 89.5				222.3 6.6 + 89.5				229.7 6.6 + 89.5				Feet
	5°	*5°-20°	*20°-35°	*35°-50°	5°	*5°-20°	*20°-35°	*35°-50°	5°	*5°-20°	*20°-35°	*35°-50°	5°	*5°-20°	*20°-35°	*35°-50°	
55.0	9.8																55.0
60.0	9.8				9.4												60.0
65.0	9.8				9.2												65.0
70.0	9.8				9.2				8.0				7.4				70.0
75.0	9.8	9.6			9.2				8.0				7.4				75.0
80.0	9.6	9.6			9.2	9.0			7.8				7.4				80.0
85.0	9.6	9.4			9.2	9.0			7.8				7.4				85.0
90.0	9.6	9.2	8.6		9.2	9.0	8.6		7.8	7.8			7.4	7.2			90.0
95.0	9.6	9.0	8.4	7.2	9.2	9.0	8.6	6.6	7.8	7.8	7.0		7.4	7.2			95.0
100.0	9.6	8.8	8.2	7.2	9.2	8.8	8.4	6.6	7.8	7.8	7.0		7.4	7.2	6.6		100.0
105.0	9.2	8.6	8.2	7.2	9.0	8.8	8.2	6.6	7.8	7.8	7.0	5.6	7.4	7.2	6.6	5.2	105.0
110.0	9.0	8.4	8.0	7.2	9.0	8.6	8.0	6.6	7.8	7.8	7.0	5.6	7.4	7.2	6.6	5.2	110.0
115.0	8.8	8.2	7.8	7.2	9.0	8.4	8.0	6.6	7.8	7.8	7.0	5.6	7.4	7.2	6.6	5.2	115.0
120.0	8.6	8.0	7.6	7.2	9.0	8.2	7.8	6.6	7.8	7.8	7.0	5.6	7.4	7.2	6.6	5.2	120.0
125.0	8.4	7.8	7.4	7.2	8.8	8.0	7.6	6.6	7.8	7.6	7.0	5.6	7.4	7.2	6.6	5.2	125.0
130.0	8.0	7.6	7.2	7.2	8.6	7.8	7.4	6.6	7.8	7.6	7.0	5.6	7.4	7.2	6.6	5.2	130.0
135.0	7.8	7.4	7.2	7.2	8.4	7.6	7.4	6.6	7.8	7.4	7.0	5.6	7.4	7.2	6.6	5.2	135.0
140.0	7.6	7.2	7.0	7.0	8.2	7.4	7.2	6.6	7.8	7.2	7.0	5.6	7.4	7.2	6.6	5.2	140.0
145.0	7.2	7.0	6.8	6.8	8.0	7.4	7.0	6.6	7.6	7.2	7.0	5.6	7.4	7.0	6.6	5.2	145.0
150.0	7.0	6.8	6.6	6.6	7.8	7.2	7.0	6.6	7.6	7.0	6.8	5.6	7.2	7.0	6.6	5.2	150.0
155.0	6.6	6.6	6.4	6.4	7.6	7.0	6.8	6.6	7.4	7.0	6.8	5.6	6.8	6.8	6.6	5.2	155.0
160.0	6.4	6.4	6.2	6.2	7.4	7.0	6.8	6.6	7.2	6.8	6.6	5.6	6.6	6.6	6.6	5.2	160.0
165.0	6.0	6.0	6.0	6.0	7.2	6.8	6.6	6.4	7.0	6.6	6.6	5.6	6.4	6.4	6.4	5.2	165.0
170.0	5.8	5.8	5.8	5.8	7.2	6.6	6.4	6.4	6.8	6.6	6.4	5.6	6.2	6.0	6.0	5.2	170.0
175.0	5.6	5.6	5.6	5.8	7.0	6.6	6.4	6.2	6.6	6.4	6.2	5.6	6.0	5.8	5.8	5.2	175.0
180.0	5.4	5.4	5.4	5.6	6.8	6.4	6.2	6.2	6.2	6.2	6.0	5.6	5.6	5.6	5.6	5.2	180.0
185.0	5.2	5.2	5.2	5.4	6.6	6.2	6.2	6.2	6.0	6.0	6.0	5.6	5.4	5.4	5.4	5.2	185.0
190.0	5.0	5.0	5.0	5.2	6.6	6.2	6.2	6.0	5.8	5.8	5.8	5.6	5.2	5.2	5.2	5.2	190.0
195.0	4.8	4.8	4.8	5.0	6.4	6.0	6.0	6.0	5.6	5.6	5.6	5.6	5.0	5.0	5.0	5.2	195.0
200.0	4.6	4.6	4.6		6.2	6.0	6.0	5.8	5.4	5.4	5.4	5.6	4.8	4.8	4.8	5.0	200.0
205.0	4.4	4.4	4.4		6.0	5.8	5.8	5.8	5.2	5.2	5.2	5.4	4.6	4.6	4.8	4.8	205.0
210.0	4.2	4.2	4.2		5.8	5.8	5.8	5.8	5.0	5.0	5.0	5.2	4.6	4.6	4.6	4.6	210.0
215.0	4.0	4.0	4.0		5.8	5.6	5.6		5.0	5.0	5.0	5.0	4.4	4.4	4.4	4.4	215.0
220.0	3.8	3.8	4.0		5.6	5.6	5.6		4.8	4.8	4.8	4.8	4.2	4.2	4.2	4.4	220.0
225.0	3.6	3.6	3.8		5.4	5.4	5.4		4.6	4.6	4.6		4.0	4.0	4.0	4.2	225.0
230.0	3.6	3.6			5.2	5.2	5.2		4.4	4.4	4.4		3.8	3.8	4.0		230.0
235.0	3.4	3.4			5.0	5.0	5.0		4.2	4.2	4.4		3.8	3.8	3.8		235.0
240.0	3.2	3.2			5.0	5.0	5.0		4.2	4.2	4.2		3.6	3.6	3.6		240.0
245.0	3.0	3.0			4.6	4.6	4.8		4.0	4.0	4.0		3.4	3.4	3.4		245.0
250.0	3.0	3.0			4.2	4.2			3.8	3.8	4.0		3.4	3.4	3.4		250.0
255.0	2.8				3.6	3.6			3.4	3.4	3.8		3.2	3.2	3.2		255.0
260.0					3.2	3.2			3.0	3.0	3.4		3.0	3.0	3.2		260.0
265.0					2.8	2.8			2.6	2.6	3.0		2.6	2.6	3.0		265.0
270.0					2.4	2.4			2.2	2.2	2.6		2.2	2.2	2.6		270.0
275.0											2.0				2.2		275.0

* Luffing under load

THIS CHART IS ONLY A GUIDE AND SHOULD NOT BE USED TO OPERATE THE CRANE.

The individual crane's load chart, operating instructions and other instructional plates must be read and understood prior to operating the crane

Load charts

Swingaway (hydraulic luffing)



52,4 m - 70,0 m
(173.1 ft - 229.7 ft)



37,3 m
(122.4 ft)



7,8 m
(25.6 ft)



360°



80 t (176,300 lb)



Pounds x 1000

Feet	173.1 6.6 + 115.8				198.3 6.6 + 115.8				222.3 6.6 + 115.8				229.7 6.6 + 115.8				Feet
	5°	*5°-20°	*20°-35°	*35°-50°	5°	*5°-20°	*20°-35°	*35°-50°	5°	*5°-20°	*20°-35°	*35°-50°	5°	*5°-20°	*20°-35°	*35°-50°	
60.0	6.6																60.0
65.0	6.6																65.0
70.0	6.6				6.4				5.2								70.0
75.0	6.4				6.4				5.2				4.8				75.0
80.0	6.4				6.4				5.2				4.8				80.0
85.0	6.4				6.4				5.2				4.8				85.0
90.0	6.4	6.4			6.4				5.2				4.8				90.0
95.0	6.4	6.4			6.2	6.2			5.2				4.8				95.0
100.0	6.4	6.4			6.2	6.2			5.2	5.2			4.8	4.8			100.0
105.0	6.4	6.2	6.0		6.2	6.2			5.2	5.2			4.8	4.8			105.0
110.0	6.4	6.0	5.8		6.2	6.2			5.2	5.2			4.8	4.8			110.0
115.0	6.4	6.0	5.6		6.2	6.0	5.8		5.2	5.0			4.8	4.8			115.0
120.0	6.2	5.8	5.4	4.6	6.2	6.0	5.6		5.2	5.0			4.8	4.8			120.0
125.0	6.2	5.6	5.4	4.6	6.2	5.8	5.4	4.4	5.2	5.0	4.8		4.8	4.8	4.4		125.0
130.0	6.0	5.6	5.2	4.6	6.2	5.6	5.4	4.4	5.2	5.0	4.8		4.8	4.8	4.4		130.0
135.0	5.8	5.4	5.2	4.6	6.0	5.6	5.2	4.4	5.2	5.0	4.8		4.8	4.8	4.4		135.0
140.0	5.8	5.2	5.0	4.6	6.0	5.4	5.2	4.4	5.2	5.0	4.8		4.8	4.8	4.4		140.0
145.0	5.6	5.2	4.8	4.6	5.8	5.2	5.0	4.4	5.2	5.0	4.8		4.8	4.8	4.4		145.0
150.0	5.4	5.0	4.8	4.6	5.6	5.2	4.8	4.4	5.2	5.0	4.8		4.8	4.8	4.4		150.0
155.0	5.2	4.8	4.6	4.6	5.6	5.0	4.8	4.4	5.0	4.8	4.6		4.8	4.6	4.4		155.0
160.0	5.0	4.8	4.6	4.6	5.4	5.0	4.8	4.4	5.0	4.8	4.6		4.8	4.6	4.4		160.0
165.0	5.0	4.6	4.4	4.4	5.2	4.8	4.6	4.4	5.0	4.6	4.6		4.8	4.6	4.4		165.0
170.0	4.8	4.4	4.4	4.4	5.2	4.8	4.6	4.4	5.0	4.6	4.4		4.8	4.4	4.4		170.0
175.0	4.6	4.4	4.2	4.4	5.0	4.6	4.4	4.4	4.8	4.6	4.4		4.6	4.4	4.4		175.0
180.0	4.4	4.2	4.2	4.2	4.8	4.4	4.4	4.4	4.8	4.4	4.2		4.6	4.4	4.2		180.0
185.0	4.2	4.0	4.0	4.2	4.8	4.4	4.2	4.2	4.6	4.4	4.2		4.4	4.2	4.2		185.0
190.0	4.0	4.0	4.0	4.0	4.6	4.4	4.2	4.2	4.6	4.2	4.2		4.2	4.2	4.2		190.0
195.0	3.8	3.8	3.8	4.0	4.6	4.2	4.2	4.2	4.4	4.2	4.0		4.0	4.0	4.0		195.0
200.0	3.6	3.6	3.6	3.8	4.4	4.2	4.0	4.2	4.2	4.0	4.0		3.8	3.8	4.0		200.0
205.0	3.4	3.6	3.6	3.6	4.4	4.0	4.0	4.0	4.2	4.0	4.0		3.6	3.8	3.8		205.0
210.0	3.2	3.4	3.4	3.6	4.2	4.0	4.0	4.0	4.0	3.8	3.8		3.4	3.6	3.6		210.0
215.0	3.2	3.2	3.4	3.4	4.2	3.8	3.8	4.0	3.8	3.8	3.8		3.4	3.4	3.6		215.0
220.0	3.0	3.0	3.2	3.4	4.0	3.8	3.8	4.0	3.6	3.6	3.6		3.2	3.2	3.4		220.0
225.0	2.8	3.0	3.0		4.0	3.8	3.8	3.8	3.6	3.6	3.6		3.0	3.2	3.2		225.0
230.0	2.6	2.8	3.0		3.8	3.6	3.6	3.8	3.4	3.4	3.4		2.8	3.0	3.2		230.0
235.0	2.6	2.6	2.8		3.8	3.6	3.6	3.8	3.2	3.4	3.4		2.8	2.8	3.0		235.0
240.0	2.4	2.4	2.6		3.6	3.6	3.6		3.2	3.2	3.2		2.6	2.8	2.8		240.0
245.0	2.2	2.4	2.4		3.6	3.4	3.6		3.0	3.0	3.2		2.6	2.6	2.8		245.0
250.0	2.2	2.2	2.4		3.4	3.4	3.4		2.8	3.0	3.0		2.4	2.4	2.6		250.0
255.0	2.0	2.2	2.2		3.4	3.4	3.4		2.8	2.8	3.0		2.2	2.4	2.4		255.0
260.0					3.2	3.2	3.4		2.6	2.6	2.8		2.2	2.2	2.4		260.0
265.0					3.2	3.2	3.4		2.6	2.6	2.8		2.0	2.2	2.2		265.0
270.0					2.8	2.8	3.2		2.4	2.4	2.6			2.0	2.2		270.0
275.0					2.4	2.4	2.8		2.0	2.0	2.4				2.0		275.0
280.0											2.2						280.0

* Luffing under load

THIS CHART IS ONLY A GUIDE AND SHOULD NOT BE USED TO OPERATE THE CRANE.

The individual crane's load chart, operating instructions and other instructional plates must be read and understood prior to operating the crane

Load charts

Swingaway (hydraulic luffing)



52,4 m - 70,0 m
(173.1 ft - 229.7 ft)



29,5/37,3 m
(96.1/122.4 ft)



7,8 m
(25.6 ft)



360°



80 t
(176,300 lb)

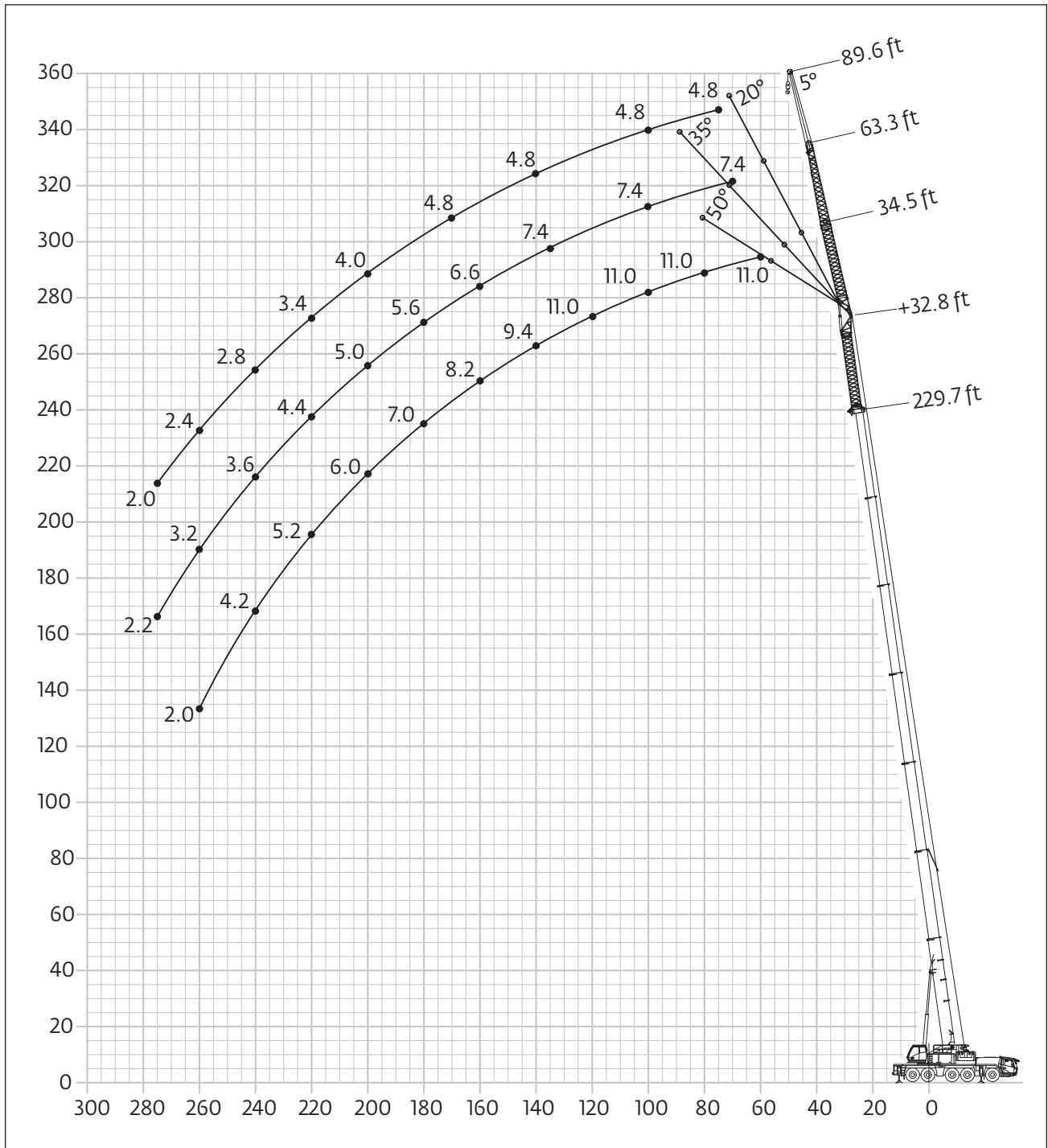

THIS CHART IS ONLY A GUIDE AND SHOULD NOT BE USED TO OPERATE THE CRANE.
The individual crane's load chart, operating instructions and other instructional plates must be read and understood prior to operating the crane

Load charts

Swingaway with boom extension (hydraulic luffing)



52,4 m - 70,0 m
(173.1 ft - 229.7 ft)



29,3 m
(96.1 ft)



7,8 m
(25.6 ft)



360°



80 t (176,300 lb)



Pounds x 1000

Feet	173.1 6.6 + 89.5				198.3 6.6 + 89.5				222.3 6.6 + 89.5				229.7 6.6 + 89.5				Feet
	5°	*5°-20°	*20°-35°	*35°-50°	5°	*5°-20°	*20°-35°	*35°-50°	5°	*5°-20°	*20°-35°	*35°-50°	5°	*5°-20°	*20°-35°	*35°-50°	
55.0	10.2																55.0
60.0	10.2				10.2												60.0
65.0	10.2				10.2												65.0
70.0	10.2				10.2				8.6								70.0
75.0	10.2				10.2				8.6				8.0				75.0
80.0	10.2				10.2				8.6				8.0				80.0
85.0	10.2				10.0				8.6				8.0				85.0
90.0	10.2	9.4			10.0				8.6				8.0				90.0
95.0	10.0	9.2			10.0	9.2			8.6				8.0				95.0
100.0	10.0	9.0	8.2		9.8	9.0			8.6				8.0				100.0
105.0	9.8	9.0	8.0		9.8	9.0	8.2		8.6	8.4			8.0	8.0			105.0
110.0	9.6	8.6	8.0		9.6	8.8	8.0		8.6	8.4			8.0	8.0			110.0
115.0	9.2	8.4	7.8	7.2	9.6	8.8	8.0		8.6	8.2			8.0	7.8			115.0
120.0	9.0	8.2	7.6	7.2	9.4	8.6	7.8	7.2	8.6	8.2	7.6		8.0	7.8	7.6		120.0
125.0	8.6	7.8	7.4	7.2	9.4	8.6	7.8	7.2	8.6	8.0	7.6		7.8	7.6	7.6		125.0
130.0	8.4	7.6	7.2	7.0	9.2	8.4	7.6	7.2	8.6	7.8	7.4		7.8	7.6	7.4		130.0
135.0	8.0	7.4	7.0	6.8	9.2	8.2	7.6	7.2	8.4	7.6	7.2	7.0	7.8	7.4	7.2	6.8	135.0
140.0	7.8	7.2	6.8	6.6	9.0	8.2	7.4	7.0	8.2	7.6	7.0	6.8	7.6	7.2	7.0	6.6	140.0
145.0	7.4	7.0	6.6	6.4	9.0	8.0	7.4	7.0	8.0	7.4	6.8	6.6	7.6	7.0	6.8	6.6	145.0
150.0	7.2	6.8	6.4	6.4	8.8	8.0	7.4	7.0	7.8	7.2	6.8	6.6	7.4	6.8	6.8	6.4	150.0
155.0	7.0	6.6	6.2	6.2	8.6	7.8	7.2	7.0	7.6	7.0	6.6	6.4	7.2	6.8	6.6	6.2	155.0
160.0	6.6	6.4	6.0	6.0	8.4	7.8	7.2	7.0	7.4	6.8	6.4	6.4	6.8	6.6	6.4	6.2	160.0
165.0	6.4	6.2	6.0	5.8	8.2	7.6	7.2	6.8	7.2	6.6	6.4	6.2	6.6	6.4	6.4	6.0	165.0
170.0	6.2	6.0	5.8	5.8	8.0	7.4	7.0	6.8	7.0	6.6	6.2	6.0	6.4	6.2	6.2	6.0	170.0
175.0	5.8	5.8	5.6	5.6	7.6	7.2	7.0	6.8	6.8	6.4	6.0	6.0	6.2	6.0	6.0	5.8	175.0
180.0	5.6	5.6	5.6	5.6	7.4	7.2	6.8	6.6	6.6	6.2	6.0	5.8	6.0	5.8	6.0	5.8	180.0
185.0	5.4	5.4	5.4	5.4	7.2	7.0	6.6	6.6	6.4	6.0	5.8	5.8	5.8	5.6	5.8	5.6	185.0
190.0	5.2	5.2	5.2	5.4	7.0	6.8	6.6	6.6	6.2	6.0	5.6	5.6	5.6	5.4	5.6	5.6	190.0
195.0	5.0	5.0	5.0	5.2	6.8	6.6	6.4	6.4	6.0	5.8	5.6	5.6	5.4	5.2	5.6	5.4	195.0
200.0	4.8	4.8	5.0	5.2	6.6	6.4	6.4	6.4	5.8	5.6	5.4	5.4	5.2	5.0	5.4	5.2	200.0
205.0	4.6	4.6	4.8		6.4	6.2	6.2	6.4	5.6	5.4	5.4	5.4	5.0	4.8	5.4	5.2	205.0
210.0	4.4	4.4	4.6		6.2	6.0	6.0	6.2	5.4	5.2	5.2	5.4	4.8	4.8	5.2	5.0	210.0
215.0	4.2	4.4	4.4		6.0	5.8	6.0	6.2	5.2	5.2	5.2	5.2	4.6	4.6	5.2	4.8	215.0
220.0	4.2	4.2	4.2		5.8	5.8	5.8		5.0	5.0	5.0	5.2	4.4	4.4	5.0	4.6	220.0
225.0	4.0	4.0	4.2		5.6	5.6	5.6		4.8	4.8	4.8	5.0	4.4	4.2	4.8	4.6	225.0
230.0	3.8	3.8			5.6	5.4	5.6		4.8	4.6	4.8	5.0	4.2	4.2	4.8	4.4	230.0
235.0	3.6	3.8			5.4	5.4	5.4		4.6	4.6	4.6	4.8	4.0	4.0	4.0	4.2	235.0
240.0	3.6	3.6			5.2	5.2	5.2		4.4	4.4	4.6		3.8	3.8	4.0	4.2	240.0
245.0	3.4	3.4			5.2	5.0	5.2		4.4	4.2	4.4		3.8	3.8	3.8		245.0
250.0	3.2	3.4			4.6	4.6	5.0		4.2	4.2	4.2		3.6	3.6	3.8		250.0
255.0	3.2				4.2	4.2	4.6		4.0	4.0	4.2		3.4	3.4	3.6		255.0
260.0					3.6	3.6			3.4	3.4	4.0		3.4	3.4	3.4		260.0
265.0					3.2	3.2			3.0	3.0	3.6		3.0	3.0	3.4		265.0
270.0					2.8	2.8			2.6	2.6			2.6	2.6	3.2		270.0
275.0					2.4				2.2	2.2			2.2	2.2	2.8		275.0

* Luffing under load

THIS CHART IS ONLY A GUIDE AND SHOULD NOT BE USED TO OPERATE THE CRANE.

The individual crane's load chart, operating instructions and other instructional plates must be read and understood prior to operating the crane

Load charts

Swingaway with boom extension (hydraulic luffing)



52,4 m - 70,0 m
(173.1 ft - 229.7 ft)



37,3 m
(122.4 ft)



7,8 m
(25.6 ft)



360°



80 t (176,300 lb)



Pounds x 1000

Feet	173.1				198.3				222.3				229.7				Feet
	6.6 + 115.8				6.6 + 115.8				6.6 + 115.8				6.6 + 115.8				
	5°	*5°-20°	*20°-35°	*35°-50°	5°	*5°-20°	*20°-35°	*35°-50°	5°	*5°-20°	*20°-35°	*35°-50°	5°	*5°-20°	*20°-35°	*35°-50°	
70.0	7.0																70.0
75.0	7.0				6.8												75.0
80.0	7.0				6.8				5.8								80.0
85.0	7.0				6.8				5.8								85.0
90.0	7.0				6.8				5.8				5.4				90.0
95.0	6.8	6.4			6.8				5.8				5.4				95.0
100.0	6.8	6.2			6.8				5.8				5.4				100.0
105.0	6.8	6.2			6.8	6.2			5.8				5.4				105.0
110.0	6.6	6.0			6.6	6.2			5.8				5.4				110.0
115.0	6.6	6.0			6.6	6.0			5.8	5.4			5.4	5.2			115.0
120.0	6.4	6.0	5.4		6.6	6.0			5.8	5.4			5.4	5.2			120.0
125.0	6.4	5.8	5.2		6.4	6.0			5.8	5.4			5.4	5.2			125.0
130.0	6.4	5.8	5.2		6.4	5.8			5.6	5.4			5.4	5.2			130.0
135.0	6.2	5.8	5.2		6.4	5.8	5.2		5.6	5.4			5.4	5.2			135.0
140.0	6.2	5.6	5.0	4.6	6.2	5.8	5.2		5.6	5.2	5.0		5.2	5.0	5.0		140.0
145.0	6.0	5.4	5.0	4.6	6.2	5.6	5.0		5.6	5.2	5.0		5.2	5.0	4.8		145.0
150.0	5.8	5.2	4.8	4.6	6.0	5.6	5.0		5.6	5.2	4.8		5.2	5.0	4.8		150.0
155.0	5.6	5.0	4.8	4.6	6.0	5.4	5.0	4.6	5.4	5.2	4.8		5.2	5.0	4.8		155.0
160.0	5.4	4.8	4.6	4.4	6.0	5.4	4.8	4.6	5.4	5.2	4.8	4.4	5.0	5.0	4.6	4.6	160.0
165.0	5.2	4.8	4.4	4.4	5.8	5.2	4.8	4.4	5.4	5.0	4.8	4.4	5.0	4.8	4.6	4.4	165.0
170.0	5.0	4.6	4.4	4.2	5.8	5.2	4.8	4.4	5.4	5.0	4.6	4.4	5.0	4.8	4.4	4.4	170.0
175.0	4.8	4.4	4.2	4.2	5.8	5.2	4.6	4.4	5.2	4.8	4.4	4.4	5.0	4.6	4.4	4.2	175.0
180.0	4.6	4.2	4.0	4.0	5.6	5.0	4.6	4.4	5.0	4.6	4.4	4.2	4.8	4.4	4.2	4.2	180.0
185.0	4.4	4.2	4.0	4.0	5.6	5.0	4.6	4.4	5.0	4.6	4.2	4.2	4.6	4.4	4.2	4.0	185.0
190.0	4.2	4.0	3.8	3.8	5.4	5.0	4.6	4.4	4.8	4.4	4.2	4.0	4.4	4.2	4.0	4.0	190.0
195.0	4.0	3.8	3.8	3.8	5.4	4.8	4.6	4.4	4.6	4.2	4.0	4.0	4.2	4.2	4.0	3.8	195.0
200.0	3.8	3.8	3.6	3.6	5.2	4.8	4.4	4.4	4.6	4.2	4.0	4.0	4.0	4.0	3.8	3.8	200.0
205.0	3.6	3.6	3.6	3.6	5.0	4.8	4.4	4.4	4.4	4.0	3.8	3.8	3.8	3.8	3.8	3.8	205.0
210.0	3.6	3.6	3.4	3.4	5.0	4.6	4.4	4.2	4.2	4.0	3.8	3.8	3.8	3.6	3.6	3.6	210.0
215.0	3.4	3.4	3.4	3.4	4.8	4.6	4.4	4.2	4.0	3.8	3.6	3.6	3.6	3.6	3.6	3.6	215.0
220.0	3.2	3.2	3.2	3.2	4.6	4.4	4.2	4.2	4.0	3.8	3.6	3.6	3.4	3.4	3.4	3.4	220.0
225.0	3.0	3.0	3.2	3.2	4.4	4.4	4.2	4.2	3.8	3.6	3.6	3.6	3.2	3.2	3.2	3.4	225.0
230.0	3.0	3.0	3.0		4.2	4.2	4.2	4.2	3.6	3.6	3.4	3.4	3.2	3.2	3.2	3.2	230.0
235.0	2.8	2.8	2.8		4.2	4.0	4.0	4.0	3.4	3.4	3.4	3.4	3.0	3.0	3.0	3.0	235.0
240.0	2.6	2.6	2.8		4.0	4.0	4.0	4.0	3.4	3.4	3.2	3.2	2.8	2.8	2.8	3.0	240.0
245.0	2.6	2.6	2.6		3.8	3.8	3.8		3.2	3.2	3.2	3.2	2.8	2.8	2.8	2.8	245.0
250.0	2.4	2.4	2.4		3.8	3.8	3.8		3.2	3.2	3.2	3.2	2.6	2.6	2.6	2.8	250.0
255.0	2.2	2.2	2.4		3.6	3.6	3.6		3.0	3.0	3.0	3.0	2.6	2.6	2.6	2.6	255.0
260.0	2.2	2.2			3.6	3.6	3.6		2.8	2.8	2.8	3.0	2.4	2.4	2.4	2.6	260.0
265.0	2.0	2.0			3.4	3.4	3.4		2.8	2.8	2.8		2.2	2.2	2.4	2.4	265.0
270.0					3.2	3.2	3.4		2.6	2.6	2.6		2.2	2.2	2.2		270.0
275.0					2.8	2.8	3.2		2.4	2.4	2.6		2.0	2.0	2.2		275.0
280.0					2.4	2.4	3.0		2.0	2.0	2.4				2.0		280.0
285.0											2.4						285.0

* Luffing under load

THIS CHART IS ONLY A GUIDE AND SHOULD NOT BE USED TO OPERATE THE CRANE.

The individual crane's load chart, operating instructions and other instructional plates must be read and understood prior to operating the crane

Specifications

Superstructure



Boom

13,3 m to 70,0 m (43.5 ft to 229.7 ft) seven-section TWIN-LOCK™ boom. Maximum tip height 73,0 m (239.5 ft).



Boom elevation

1 cylinder with safety valve, boom angle from -1.5° to +82°.



Load moment and independent anti-two block system

Load moment and independent anti-two block system with audio visual warning and control lever lock-out. These systems provide graphic display of boom angle, length, radius, tip height, relative load moment, maximum permissible load, load indication and warning of impending two-block condition with lock-out hoist function.



Cab

Aluminium, full vision, tiltable (approx. 20°), safety glass, adjustable operator's seat with suspension, engine-independent heater. Armrest-integrated crane controls. Ergonomically arranged instrumentation and crane operating controls.



Slewing

3 slewing gears with axial piston motors, planetary gears, automatic break.



Counterweight

80 tonnes (176,300 lb), consisting of various sections (50 t [110,200 lb] within 3,00 m [9.84 ft] vehicle width). Hydraulic removal system.



Hydraulic system

2 separate circuits, 1 axial piston variable displacement pump with electronic power limiting control and axial piston variable displacement pump for slewing. Thermostatically controlled oil cooler. Tank capacity: 890 l (235 gallons).



Control system

Full electronic control of all crane movements using electrical control levers with automatic reset to zero. Integrated with the RCL and engine management system by CAN-BUS. Crane Control System (CCS) with system with graphic display. Crane Star telematics system.



Hoist

Axial piston motor with planetary gear and brake. Drum rotation indicator. Hoist camera with light.

* Optional equipment

- Bi-fold swingaway, 12/21 m (39/69 ft)- with hydraulic offset and luffing under load (5° - 50°), controlled from the crane cab.
- Boom extension, jib extension(s) 29/37 m (95/121 ft), consisting of bi-fold swingaway and 2 boom/jib extensions.
- Auxiliary hoist, self-rigging via counterweight
- Auxiliary boom nose using one part of line
- Auxiliary boom nose using two parts of line
- Air-conditioning system
- 2,0 m (6.6 ft) side stowed stub jib using 4 parts of line. Offset 8° and 30°

Carrier



Chassis

Special five-axle chassis, all-welded torsion-resistant box type construction in high strength steel.



Outriggers

4 double hydraulically telescoping beams with vertical cylinders and outrigger pads. Independent horizontal and vertical movement control on each side of the carrier and from the operators cab. Electronic level indicator with automatic levelling system.



Engine

Mercedes Benz OM471LA, diesel, six cylinders, water cooled, turbocharged, 390 kW (532 HP) at 1700 rpm (80/1269 EWG fan loose). Max. torque: 2460 Nm (1814 ft lb) at 1300 rpm. Fuel tank: 300 l + 350 l (79 + 92,5 gallons). Engine emission: Euromot 4 / EPA / CARB Tier 4 final (non-road).



Transmission

Mercedes G 280 with VIAB -16 gears forwards and 2 reverse. 1-stage transfer case with longitudinal differential lock and VIAB turbo retarder coupling.



Drive/Steer

10 x 6 x 10.



Axle lines

5 axle lines, axle lines 2, 4 and 5 steered and driven. Axle lines 1 and 3 steered.



Suspension

MEGATRAK®. All wheels with independent hydropneumatic suspension and hydraulic lockout. Longitudinal and transverse level control with automatic on highway levelling system. Range +170 mm/-130 mm (6.69 in/-5.12 in). Active suspension control on outrigger control units.



Tires

10 tires, size 445/95 R25 (16.00 R25).



Steering

Dual circuit, hydraulic power assisted steering with emergency steering pump. Axle lines 1, 2, 3 and 5 steer on highway (steer by wire). Separate electronic hydraulic (steer by wire) steering of the 4th, and 5th axle line for all wheel steering and crabbing.



Brakes

Service brake: pneumatic dual circuit disc brakes acting on all wheels, air dryer. Permanent brake: exhaust brake and constant throttle brake. Parking brake: pneumatically operated spring-loaded brake acting on axle lines 2, 3, 4 and 5.



Driver's Cab

Composite designed aluminium and fibre reinforced plastic, 2-person-design, safety glass, driver seat with pneumatic suspension, engine-dependent hot water heater. Complete instrumentation and driving controls. Air condition. 12 V plug. Two rotating beacons. Fire extinguisher.



Electrical system

Three-phase alternator 28 V/100A, 2 batteries 12 V/170 Ah. Lighting system and signals 24 V.

* Optional equipment

- 10 x 8 x 10
- 10 tires, size 445/95 R25 (16.00 R25).
- 10 tires, size 525/80 R25 (20.5 R25). - Vehicle width 3,10 m (10.17 ft)
- Folding bunk bed in carrier cab.
- Engine-independent hot water heater, with engine pre-heater.
- Reverse camera system.

* Other optional equipment on request.

The lifting capacities correspond to ASME 30.5

The lifting capacities likewise fulfil the requirements of SAEJ1289 and ISO 4305 with regard to stability.

The lifting capacities are given in 1,000 lbs.

Lifting capacity = Payload + weight of hook block and suspending device.

The lifting capacities for the main boom only apply with the jib dismantled.

Lifting capacities > 133 t (294,000 lb) require additional equipment.

Lifting capacities > 179 t (394,000 lb) require special equipment.

The right is reserved to modify the load-carrying capacities.

Note: The details in this brochure serve only as general information. The determinant values for the operation of the crane are the lifting capacity tables belonging to it and the operating instructions.

Lifting capacities are indicated by boom length for different levels of extension. The actual boom length will be in accordance with the selected configuration for boom extension.

Symbols glossary



Axles



Counterweight



Main hoist



Outriggers



Axle load



Crane functions



Auxiliary hoist



Radius



Boom



Crane travel



Hookblock / Capacity



Slewing/Working range



Boom elevation



Drive/Steer



Hydraulic system



Speed



Boom telescoping



Electrical system



Lattice extension



Suspension



Brakes



Engine



Lattice extension (luffing)



Transmission / Gear



Cab



Free on wheels



Luffing Jib



Travel speed



Carrier frame



Gradeability



Low range



Tyres

Manitowoc Cranes

Regional headquarters

Americas

Manitowoc, Wisconsin, USA

Tel: +1 920 684 6621

Fax: +1 920 683 6277

Shady Grove, Pennsylvania, USA

Tel: +1 717 597 8121

Fax: +1 717 597 4062

Europe, Middle East, Africa

Dardilly, France

Tel: +33 (0)4 72 18 20 20

Fax: +33 (0)4 72 18 20 00

China

Shanghai, China

Tel: +86 21 6457 0066

Fax: +86 21 6457 4955

Greater Asia-Pacific

Singapore

Tel: +65 6264 1188

Fax: +65 6862 4040



Manitowoc Crane Care when you need it.

The assurance of the world's most advanced crane service and support to get you back to work fast.



Manitowoc Finance helps you get right to work generating profits for your business.

Financial tools that help you capitalize on opportunity with solutions that fit your needs.

This document is non-contractual. Constant improvement and engineering progress make it necessary that we reserve the right to make specification, equipment, and price changes without notice. Illustrations shown may include optional equipment and accessories and may not include all standard equipment.